

PRODUCT CATALOGUE

ACTIVE FIRE AND SMOKE
CURTAIN BARRIER ASSEMBLIES

WWW.COOPERSFIRE.COM



coopers

EST. 1983

LEADING THE WAY IN FIRE PROTECTION

PRODUCT CATALOGUE

CONTENTS

Product Matrix	page 4	FireMaster® Marine A-0	page 30
Company Profile	page 6	SmokeStop D600A	page 32
Applications	page 10	SmokeStop DH60	page 34
FireMaster®	page 12	SmokeStop evacU8® D600A	page 36
FireMaster® ResQ-Window™	page 14	SmokeStop Concertina™ DH60/D60	page 38
FireMaster® Plus ²	page 16	Coopers SmokeStop® Draft Curtain	page 40
FireMaster® Cleanroom	page 18	Coopers SmokeStop® Egress Draft Curtain	page 42
FireMaster® Concertina™	page 20	Vii®Fire FM (Door, Serve and Cabin)	page 44
FireMaster® NVS™ Horizontal	page 22	Vii®Fire iZone	page 46
FireMaster® Plus NVS™ Horizontal	page 24	Electrical Controls	page 48
FireMaster® SuperPlus™	page 26	Electrical Controls - Optional Extras	page 50
FireMaster® Egress	page 28	Contact Coopers	page 52



FIRE AND SMOKE CURTAINS

PRODUCT MATRIX

These tables will help assist you with the type of fire or smoke curtain product required.

BS 8524-1 FIRE CURTAINS

PRODUCT NAME	ORIENTATION	MAX WIDTH	MAX DROP	FIRE RESISTANCE OR CLASSIFICATION	SMOKE CONTROL
FIREMASTER®	Vertical - Single Roller	5m	8m	E180 EW30	Yes*
FIREMASTER®	Vertical - Overlapping Rollers	Unlimited	6m	E120 EW30	No
FIREMASTER®	Vertical - Overlapping Rollers	8m	8m	E120 EW30	No
FIREMASTER® PLUS²	Vertical - Single Roller	5m	8m	E180 EW90	Yes*
FIREMASTER® PLUS²	Vertical - Wide Single Roller	20m	4m	E180 EW90	Yes*
FIREMASTER® CONCERTINA	Concertina - Open	Unlimited	5m	E180 EW30	No
FIREMASTER® CONCERTINA	Concertina - Open	Unlimited	8m	E120 EW30	No
FIREMASTER® CONCERTINA	Concertina - Closed	Unlimited	5m	E240 EW30	No
FIREMASTER® CONCERTINA	Concertina - Closed	Unlimited	8m	E120 EW30	No
VII®FIRE	Vertical - Single Roller	4m	4m	E120 EW30	Yes*
VII®FIRE IZONE	Vertical - Single Roller	4m	4m	E180 EW60	Yes*

* Approved to BS EN 1634-3, Fire resistance and smoke control tests for door and shutter assemblies, openable windows and elements of building hardware. Smoke control test for door and shutter assemblies.

UL TESTED FIRE AND DRAFT CURTAINS

PRODUCT NAME	ORIENTATION	MAX WIDTH	MAX DROP	FIRE RESISTANCE OR CLASSIFICATION	SMOKE CONTROL
FIREMASTER®	Vertical - Single/Overlapping Rollers	Unlimited	8m	180 mins	Yes
FIREMASTER® EGRESS	Vertical - Single/Wide Single Roller	18m	7m	180 mins	Yes
FIREMASTER® CONCERTINA	Concertina - Open/Closed	Unlimited	8m	180 mins	No
COOPERS SMOKESTOP® DRAFT CURTAIN	Vertical - Single/Overlapping Rollers	Unlimited	8m	N/A	Yes
COOPERS SMOKESTOP® EGRESS	Vertical - Single/Wide Single Roller	18m	7m	N/A	Yes

The tables above represent maximum product certification dimensions for each product model. For maximum possible working dimensions please contact Coopers Fire.

FIRE AND SMOKE CURTAINS

PRODUCT MATRIX

These tables will help assist you with the type of fire or smoke curtain product required.

BS EN 1634-1 FIRE CURTAINS

PRODUCT NAME	ORIENTATION	MAX WIDTH	MAX DROP	FIRE RESISTANCE OR CLASSIFICATION	SMOKE CONTROL
FIREMASTER®	Vertical - Single Roller	7m	8m	E120 EW30	Yes*
FIREMASTER®	Vertical - Single Roller	7m	7m	E180 EW30	Yes*
FIREMASTER®	Vertical - Overlapping Rollers	Unlimited	6m	E120 EW30	No
FIREMASTER®	Vertical - Single/Overlapping Rollers	Unlimited	8m	E120 EW30	No
RESQ-WINDOW™	Vertical - Single Roller	2.6m	2.8m	E120 EW30	No
FIREMASTER® PLUS²	Vertical - Single Roller/Wide Single Roller	7m	5m	E120 EW90	Yes*
FIREMASTER® PLUS²	Vertical - Single Roller/Wide Single Roller	7m	4m	E180 EW90	Yes*
FIREMASTER® CLEANROOM	Vertical - Single Roller	2.6m	2.8m	E120 EW120	No
FIREMASTER® MARINE	Vertical - Single Roller	2.692m	2.4m	A-0	No
FIREMASTER® HORIZONTAL	Horizontal - Simplex	Contact Coopers		Contact Coopers	No
FIREMASTER® HORIZONTAL	Horizontal - Duplex	Contact Coopers		Contact Coopers	No
FIREMASTER® PLUS HORIZONTAL	Horizontal - Simplex	Contact Coopers		Contact Coopers	No
FIREMASTER® PLUS HORIZONTAL	Horizontal - Duplex	Contact Coopers		Contact Coopers	No
FIREMASTER® SUPERPLUS	Vertical - Single/Overlapping Rollers	On Request	3m	EI30 (EI120 through assessment)	No

* Approved to BS EN 1634-3, Fire resistance and smoke control tests for door and shutter assemblies, openable windows and elements of building hardware. Smoke control test for door and shutter assemblies.

EN 12101 SMOKE CURTAINS

PRODUCT NAME	ORIENTATION	MAX WIDTH	MAX DROP	FIRE RESISTANCE OR CLASSIFICATION
COOPERS SMOKESTOP®	Vertical - Single Roller	6m	8m	D600A
COOPERS SMOKESTOP®	Vertical - Overlapping Rollers	Unlimited	10.5m	D600A
COOPERS SMOKESTOP®	Vertical - Single Roller	6m	8m	DH60
COOPERS SMOKESTOP®	Vertical - Overlapping Rollers	Unlimited	10.5m	DH60
COOPERS SMOKESTOP®	Vertical - Side by Side Overlapping	Unlimited	6.7m	D600A
COOPERS SMOKESTOP® EVACU8	Vertical - evacU8	Unlimited	6.7m	D600A
COOPERS SMOKESTOP® CONCERTINA	Concertina - Open/Closed	Unlimited	6m	DH60/D60

The tables above represent maximum product certification dimensions for each product model. For maximum possible working dimensions please contact Coopers Fire.

COOPERS FIRE LTD.

COMPANY PROFILE

Coopers Fire operate from two factories in the UK, one in Elland and the main office and factory in Havant. Coopers Fire offer product design, manufacture, installation, commissioning and on-going servicing of fire and smoke barriers.

With a long established history we are now represented in over 40 overseas territories through a distributor network that spans over 20 years. The Management Team is committed to quality and every product is rigorously inspected to ensure that it meets with the project requirements.

Coopers Fire were the original patentees of the electromechanical fail safe system, which set the benchmark for active smoke and fire barriers worldwide, and help us to continue to remain a market leader based upon our unique and patentable systems.

Coopers Fire offer an unparalleled range of vertical and horizontal smoke and fire curtain barrier systems that are tested extensively in many different countries to many international standards to meet a wide regulatory field.

COOPERS FIRE LTD. IS A SPECIALIST MANUFACTURER OF SMOKE AND FIRE CURTAIN BARRIER SYSTEMS.

COMPANY HISTORY

Coopers was originally a family business manufacturing blinds and shutters dating back to 1874.

Coopers Fire Ltd, invented and patented the automatic fire screen with gravity fail-safe drive system in 1983 and sparked a generation of smoke and fire barriers. Now an industry norm, active smoke and fire barriers are available worldwide.

Coopers Fire comply with ISO 9001 for Quality Management Systems and ISO 14001 for Environmental Management Systems.

Continuous research and development has resulted in Coopers Fire always being first in their industry to comply with BS 7346-3 and CE Mark to EN 12101-1 for smoke barriers. The first to comply with BSI PAS 121 and now BS 8524 for fire curtain barriers.

Coopers Fire was bought by the Lowe & Fletcher Group in 2014, who are a fifth generation family owned industrial business which was founded in 1889.



The Engineering Department is fully equipped with 3D and 2D facilities and can provide customised services right from concept and design stage to completion and beyond. Coopers Fire provide a number of technical experts that are extensively involved in ISO, CEN and BS standards.

Unlike other suppliers, Coopers Fire pride themselves on innovation and bespoke solutions which are supported by numerous internationally accredited Independent Third Party Certification Schemes for both Product and Installation where applicable.



COOPER'S INTERNATIONAL LANDMARKS

A long history of many prestigious international landmark buildings are protected by Coopers Fire smoke and fire curtains.

Some of the iconic buildings Coopers Fire products are installed in are the Sydney Opera House, The Louvre in Abu Dhabi, Royal Palaces at Buckingham, Windsor, and St. James, London's iconic buildings like The Shard, The British Museum and The Gherkin and large shopping malls like The Mall of the Emirates and the Dubai Mall.

Coopers Fire have curtains in International Airports such as Sydney, Brisbane, Dulles, Heathrow, Gatwick, Stansted, Ataturk, Johannesburg, Dusseldorf, Chek Lap Kok, and Dubai Terminal 3.

Coopers Fire have also installed fire and smoke curtains in commercial buildings, offices and retail stores for brands such as Apple, Adidas, Google, McDonalds, Selfridges, Fortnum and Mason and Facebook.

TESTING AND STANDARDS

At Coopers Fire, our commitment to life safety is best expressed through our dedication to ensuring that Coopers Fire fire and smoke curtains meet the highest international standards.

Coopers Fire test and manufacture every fire and smoke curtain in accordance with the toughest of internationally recognised accreditations, instilling clients with confidence in fire protection equipment that they can trust.



certifire



QUALITY

As one of the world's leading innovators and specialists in smoke and fire barrier technology, Coopers Fire Ltd. manufactures active smoke and fire barriers which are fully tested and certified to the latest fire regulations and building design technology.

All employees from top down are fully committed to supply, manufacture, install, commission and service our products to meet our customers' requirements. In order to ensure that we achieve excellence in all our processes, we implement a Quality Management System to best practices.



The Quality Policy is communicated to all employees and compliance to this Quality Management System is compulsory to all employees. The Policy is reviewed annually or as the circumstances dictate due to any significant changes for continuing suitability. Coopers Fire have been accredited to ISO 9001 for over 20 years.

THE QUALITY MANAGEMENT SYSTEM ENSURES THAT:

- Our customers needs are fully understood;
- Appropriate resources are provided in terms of facilities and relevant skill to fulfil customer needs;
- Quality objectives are set which are consistent with the overall policies of the Company. The progress towards objectives are continuously monitored;
- The Company is committed to continuous improvement with an aim of customer satisfaction beyond expectations.



If you wish to read the full Coopers Fire Quality and Environmental Policy, please visit the Coopers Fire website - www.coopersfire.com

ENVIRONMENTAL

All employees from top down are committed to the care of the environment and the prevention of pollution. The company ensures that all its processes are carried out in conformance with all relevant legislation and other requirements.



The Environmental Policy is communicated to all employees and compliance to this Quality Management System is compulsory to all employees. The Policy is reviewed annually or as the circumstances dictate due to any significant changes for continuing suitability. Coopers Fire have been accredited to ISO 14001.

The company seeks to minimise waste arising, promote recycling, reduce energy consumption for end-users, reduce harmful emissions and use of environmentally friendly packaging materials, and where possible, to work with suppliers and subcontractors who themselves have sound environmental policies.

An essential feature of the environmental management system is a commitment to improving environmental performance. This is achieved by setting annual environmental improvement objectives and targets which are regularly monitored and reviewed. The objectives and targets are publicised throughout the company and all our employees are committed to their achievement.

This Policy and the obligations and responsibilities required by the environmental management system are communicated to all employees and others working on behalf of Coopers Fire Ltd.

HEALTH & SAFETY

Our Health and Safety Systems are based on a belief that the well-being of our employees, or people affected by our work, is a major priority and must be considered during all work performed on our behalf.

THE OBJECTIVES OF OUR HEALTH & SAFETY POLICY:

- To abide by all aspects of the Health & Safety Act 1974
- To achieve an accident and incident free workplace
- To make health and safety an integral part of every managerial and supervisory position
- To ensure health and safety is considered in all planning and work activities
- To involve our employees in the decision making processes through regular communication, consultation and training
- To identify and control all potential hazards in the workplace through hazard identification and risk analysis
- To ensure all potential accident/incidents are controlled and prevented
- To provide effective injury management and rehabilitation for all employees

BENEFITS OF SMOKE AND FIRE BARRIERS

- Designed to protect life and property
- Unparalleled opening sizes that can be protected
- Can offer far better radiant heat reduction properties than steel roller shutters
- Far less wear and tear, with less servicing required than alternative products
- Small, compact housing blends into the building structure
- Reliable and adaptable to many different applications
- Safer than heavy and dangerous steel roller shutters
- Can be adapted to suit existing construction
- Automatically activated by smoke or fire detection
- Fail-safe by gravity unlike other products
- Complies with and exceeds testing requirements
- Can be added to existing, non-compliant separating elements e.g. in conjunction with a non-compliant fire door or fire shutter
- Building Management Systems compatible with Fireman's Override
- Cost effective standard size units available
- Many addition control features available, all of which have been rigorously tested and proven to work over 3 decades
- Custom made to measure solutions where exact size and project specific requirements are met.

APPLICATIONS FOR FIRE AND SMOKE CURTAINS

Coopers Fire have developed a wide range of fire and smoke curtains to protect every type of building application. From protecting means of escape and boundary protection to providing a building with a system that offers effective fire and smoke compartmentation.

Commitment to life safety has led Coopers Fire to develop a wide range of fire and smoke curtains fully tested to BS EN and UL standards and approved to protect various applications across a wide spectrum of building types such as retail, healthcare, commercial, airports and domestic.

Fire and Smoke curtains offer various solutions to architects, engineers, consultants and specifiers providing the ability to design complex buildings that adhere to fire regulations and offer protection against fire or smoke. When specifying a fire or smoke curtain system, it is essential to consider the whole package from quality, performance, installation and service to after sales care. Coopers Fire offers third party certificated products as well as third party accredited installation and specialist after care service packages, tailored to your specific requirements and application.

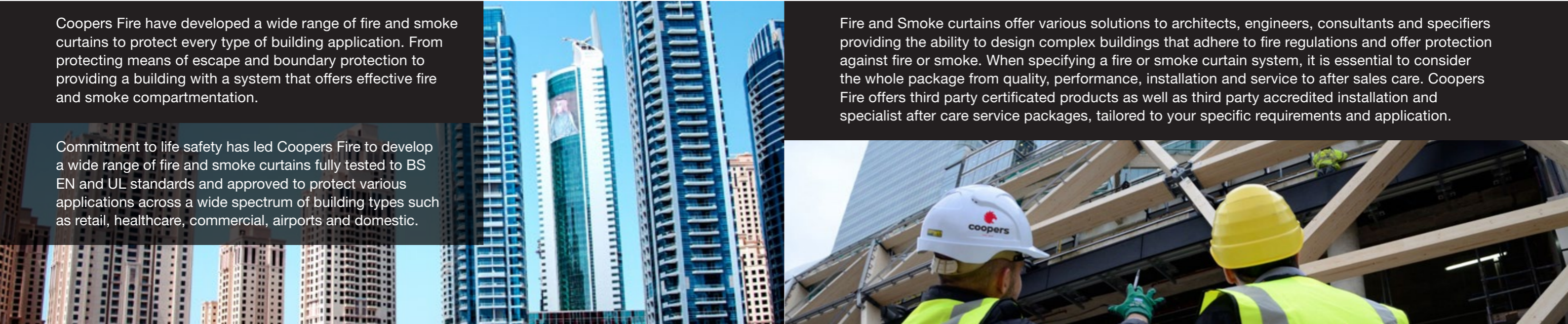

ATRIUM, LOBBIES & RECEPTIONS

Prevent the spread of smoke and fire from one to floor to another in an atrium with Coopers Fire Horizontal or Concertina curtains or protect lobbies and receptions using Vertical fire and smoke curtains.



OPENINGS IN WALLS

Coopers Fire fire curtains can be used to replace non-load bearing walls and fire rated glazing offering open plan designs that still meet fire regulations.



COMPARTMENTATION

Coopers Fire full range of fire and smoke curtains can be used to create compartments to contain fire and smoke and prevent it from spreading. The product range is used particularly in this instance in large open spaces in buildings.



LIFTS AND LIFT LOBBIES

Coopers Fire knowledge of the regulations protecting lifts and lift lobbies has led to the development of a range of Vertical fire curtains with smoke control approved to protect the spread of fire and smoke through lift shafts.



EGRESS & CORRIDOR SEPARATION

Protect escape routes for mass evacuation. The evacu8 smoke curtain allows egress through a compartment that contains smoke. It offers the capability to split deployment to encourage safe evacuation psychology where assemblies cross potential escape routes.



BOUNDARY PROTECTION

Coopers Fire fire curtains are an approved alternative to fire shutters, fire rated glazing and firewalls whilst protecting windows from channeling fire and preventing the spread of fire from one building to the next.



STAIRS AND ESCALATORS

Open up stairwells or protect escalators by using Vertical or Concertina fire and smoke curtains. The Concertina product has been used to fully encapsulate stairs or escalators to allow open plan designs, replacing fire doors and lobbies.



PROTECTED MEANS OF ESCAPE

Coopers Fire commitment to advancing fire fabric technology has led us to develop a range of insulating zone fire curtains that provide architects and fire engineers with a non-invasive, protected means of escape, in accordance with fire regulations.

FIREMASTER®

FIREMASTER®

The FireMaster fire curtain is one of the most popular products produced by Coopers Fire and is used in a variety of applications. The standard fabric used offers 240 minutes integrity under BS 476-22.8:1987 and the A1 rated fabric can be offered which has an integrity rating of 180 minutes for a single curtain system and 120 minutes for an overlapping curtain system under BS 8524-1:2013.

The FireMaster fire curtain is compliant to BS 8524 Part 1 and Part 2 for both a single width and overlapping widths. Our BS 8524 compliant products use the ground breaking A1 fire fabric Coopers Fire have engineered and they also feature other innovative solutions to ensure compliance with this rigorous British Standard for fire curtains.

The FireMaster is also compliant to test standards UL 10B, UL 10C, UL 10D, UL 1784 and NFPA 252.

Active Fire Curtain Barrier Assemblies comprise technologically advanced fire-resistant fabric barriers encased in a compact steel housing. Barriers remain invisibly retracted until activated by an alarm or detector signal, at which time they descend safely to their fire operational position.

To be compliant, Fire Barriers must be protected from a short circuit and or total power failure, this is achieved with our patented Total Gravity Fail-Safe (TGFS) system.

Fire barriers will stop and control the spread of fire in a building. If means of escape protection is required use FireMaster Plus².

THE ORIGINAL FIRE RATED BARRIER SOLUTION TESTED TO BS EN AND UL STANDARDS
UNLIMITED WIDTHS AVAILABLE

See the Product Matrix on pages 4 and 5 for Classifications and Maximum Width and Maximum Drops available

FireMaster is designed to prevent the spread of fire in accordance with BS 8524-1:2013 and UL 10D

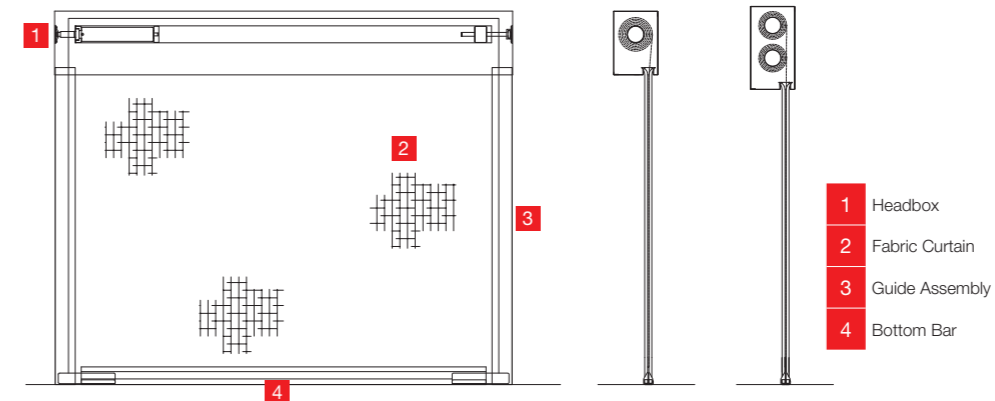

PRODUCT APPLICATION

ATRIA: Where there are more than 2 interconnected floors or the floor area exceeds 2,000m²

SHOP FRONTS: No need for expensive fire-rated glass

STAIRS & ESCALATORS: Remove non-loadbearing fire-rated walls, doors or shutters

BOUNDARY PROTECTION: Eliminate fire spread to other buildings.

PRODUCT ADVANTAGES

- Compliant to the only fire curtains British Standard, BS 8524 Part 1
- Small lightweight headboxing
- Can protect very large open spaces without the need for heavy structural supports
- Can easily retro-fit into heritage buildings
- Patented TOTAL fail-safe by gravity which means they will work when required
- Ease of service

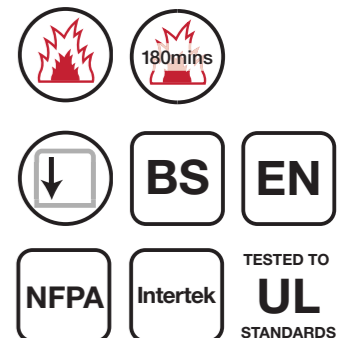

ResQ-WINDOW™

The ResQ-Window™ can be installed into a Coopers Fire fire curtain allowing building occupants and first responders to see through the curtain after it has been deployed.

ResQ-Window™ can withstand temperatures in excess of 1000°C with 2 hours integrity (E120).

The curtain with a vision panel is designed for:

- Escape routes incorporating doorways and corridors
- Lift openings and lobbies
- Areas where Fire Marshals and the Fire and Rescue Service may need to assess prior to entry

BS 9999 and Approved Document B both reference the requirement and benefits of vision panels used in fire safety in occupied buildings.

The ResQ-Window™ can be positioned to allow a low and high level view through the curtain if required.

ResQ-WINDOW™ IS A PATENTED TRANSLUCENT FIRE PROOF FLEXIBLE MATERIAL CREATED TO ADDRESS THE NEED FOR A VISION PANEL IN A DEPLOYABLE FIRE CURTAIN SYSTEM.

See the Product Matrix on pages 4 and 5 for Classifications and Maximum Width and Maximum Drops available



The ResQ-Window™ is tested and compliant to BS EN 1634-1, third party approved through Exova's Certifire scheme and certified to **E120 EW30 (120 mins fire resistance and 30 mins radiant heat)**.

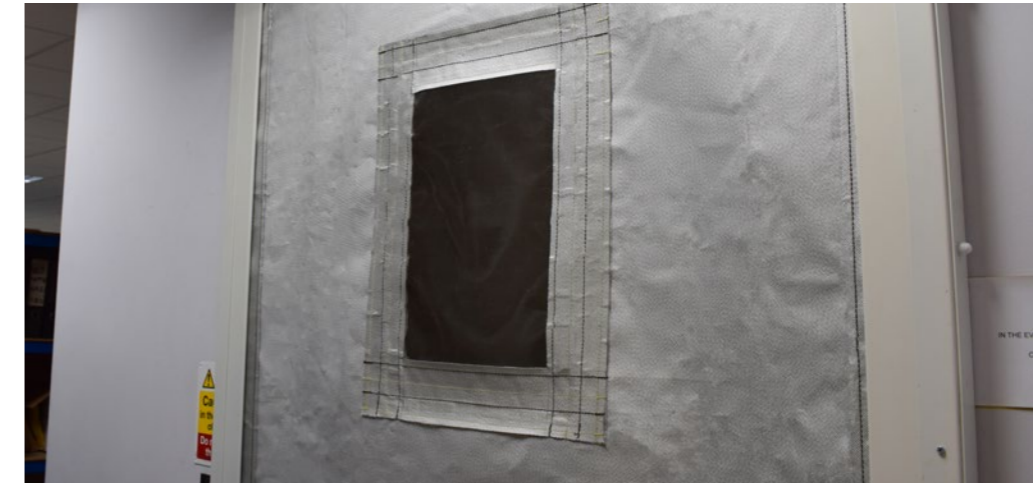
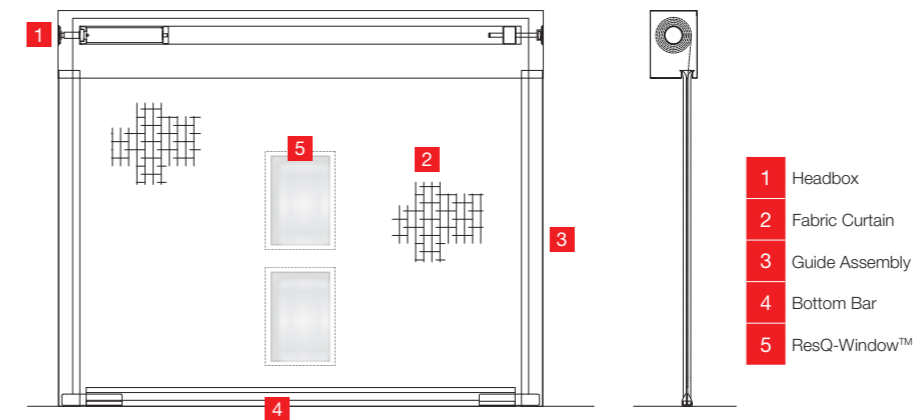

PRODUCT APPLICATION

- Cross corridor separation
- Lift openings and lobbies
- Openings in walls
- Egress

PRODUCT ADVANTAGES

- See through a deployed curtain as a means of escape
- Safely egress from lifts
- Suitable for lift lobby muster points
- First responder can clear a building faster
- First responder can see the presence of an occupant on the other side of a curtain
- First responder can see the presence of fire on the other side of a curtain
- First responder can see the presence of smoke on the other side of a curtain

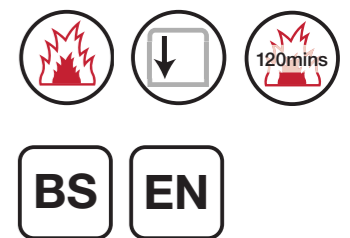

FIREMASTER®

PLUS²

The FireMaster Plus² is a more advanced fire curtain due to the intumescent fire fabric used. The fabric used with the FireMaster Plus², when exposed to temperatures above 160°C, forms a rapid expanding carbonaceous char of organic matter and consequently provides a thermal insulating barrier. The thermal insulating barrier creates a tenable zone allowing occupants of a building to safely pass the curtain to safety with a fire burning the other side of the fire curtain.

FireMaster Plus² is an Active Fire Curtain Barrier Assembly comprising of technologically advanced fire-resistant fabric barriers encased in a compact steel housing. Barriers remain invisibly retracted until activated by an alarm or detector signal, at which time they descend safely to their fire operational position.

To be compliant, Fire Barriers must be protected from a short circuit and or total power failure, this is achieved with our patented Total Gravity Fail-Safe (TGFS) system.

Fire barriers will stop and control the spread of fire in a building. FireMaster Plus² should be used if means of escape protection is required.

HEAT PROTECTION FIRE BARRIERS OFFERING MEANS OF ESCAPE PROTECTION

See the Product Matrix on pages 4 and 5 for Classifications and Maximum Width and Maximum Drops available

FireMaster Plus² reduces radiant heat to less than 10 kW/m² after 60 minutes. FireMaster Plus² is designed to prevent the spread of fire in accordance with BS 8524-1:2013.

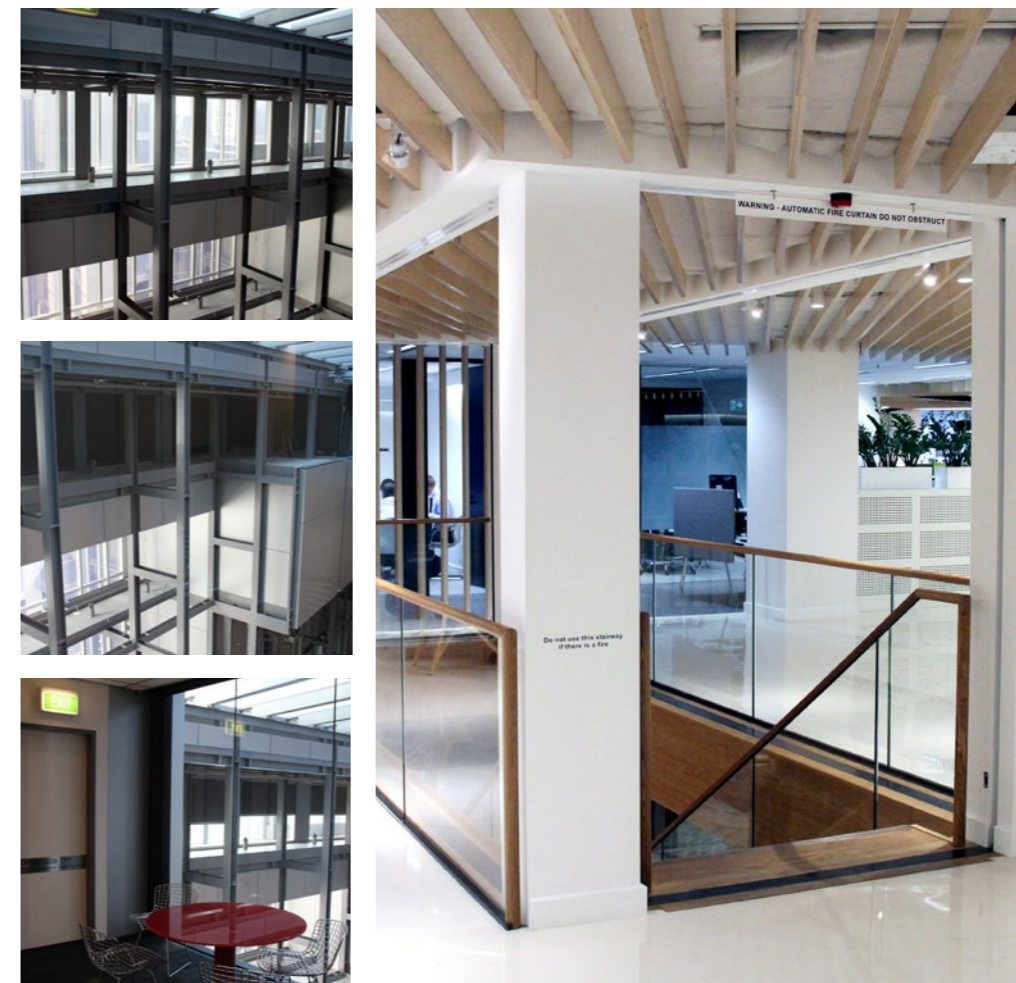
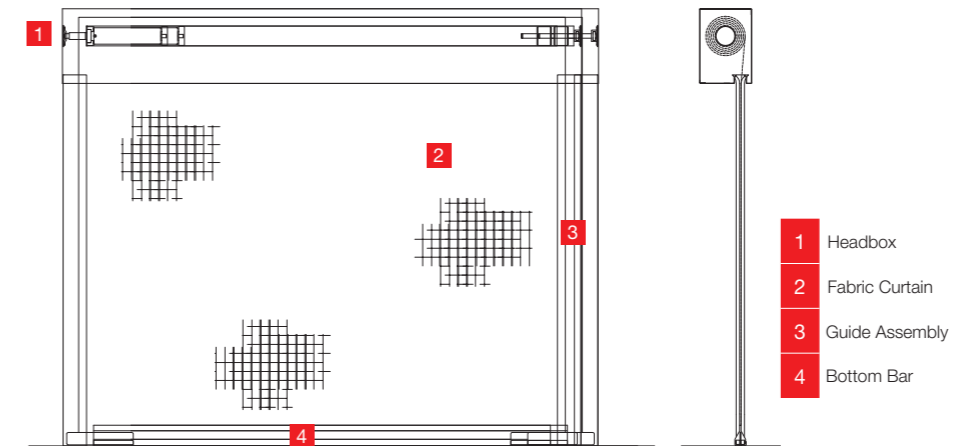

PRODUCT APPLICATION

- Protect means of escape
- Protect near combustibles
- Protect non-fire rated glass
- Basement car parks

PRODUCT ADVANTAGES

- Compliant to the only fire curtains British Standard, BS 8524 Part 1
- Provides insulating zone performance
- Does not require sprinklers or drenchers to reduce heat
- Increases valuable floor space
- Remove non-loadbearing walls/partitions to create wide open spaces
- Remove fire doors to make free flowing corridors
- Remove lift and stair lobbies
- Patented TOTAL fail-safe by gravity which means they will work when required
- Ease of service



FIREMASTER®

CLEANROOM

The FireMaster Cleanroom fire curtain is the world's first active fire curtain certified as suitable for all types of cleanroom environments in a variety of industries such as pharmaceutical, microelectronics, aerospace, medical and telecoms.

The FireMaster Cleanroom is fire resistant for 2 hours and certified as suitable for use in cleanrooms fulfilling the specifications of Air Cleanliness Class 6, according to ISO 14644-1.

The FireMaster Cleanroom is manufactured from 316L grade stainless steel suitable for use in a cleanroom environment. The FireMaster Cleanroom features a stainless steel curtain that does not release particles in operation and features side guides that can be manually opened and closed for cleaning.



A FIRE CURTAIN CERTIFIED FOR USE IN CLEANROOM ENVIRONMENTS THAT CAN BE EASILY CLEANED AND PREVENT THE SPREAD OF FIRE

See the Product Matrix on pages 4 and 5 for Classifications and Maximum Width and Maximum Drops available



The FireMaster Cleanroom fulfils the specifications of Air Cleanliness Class 6 to ISO 14644-1 and has been tested for chemical resistance to ISO 4628-1 for both the Stainless Steel Curtain and Structure (headbox and side guides).

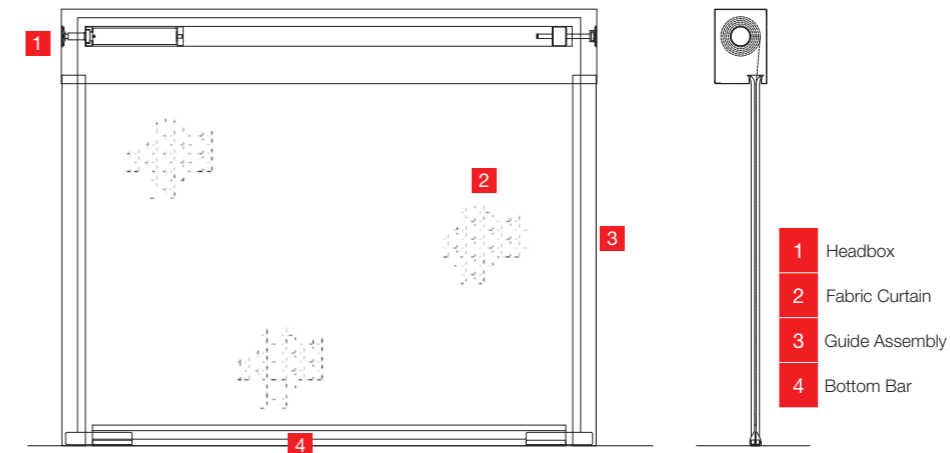

PRODUCT APPLICATION

- Boundary protection
- Cross corridor separation
- Means of escape
- Compartmentation

PRODUCT ADVANTAGES

- Certified for use in cleanroom environments
- Replace fire rated walls and doors allowing for open plan designs
- Protect non-fire rated walls and glazing and openings in walls
- Suitable for all cleanrooms up to ISO 6, Class 1,000 classification
- Fire resistance for up to 2 hours
- Manufactured from materials resistant to harsh cleanroom cleaning chemicals
- Out of room controls and accessories
- Retrofit or new build installations
- Easily cleaned



FIREMASTER®

CONCERTINA™

The revolutionary FireMaster Concertina provides the same protection as a steel fire shutter but at a fraction of the size and weight, with no need for columns or corner posts and intrusive ceiling interfaces. This innovative design gives architects, consultants, specifiers and owner/occupiers a whole new way to approach building design, maximising floor space and increasing rental income.

The FireMaster Concertina is available in Open and Closed shapes. The Open Concertina has at least one open side and requires side channels. Common Open Concertina curtains are L, U shapes. The Closed Concertina is fully enclosed and does not require side channels. Common Closed Concertina curtains are square, rectangular and circular (multi-faceted) shapes.

Active Fire Curtain Barrier Assemblies comprise technologically advanced fire-resistant fabric barriers encased in a compact steel housing. Barriers remain invisibly retracted until activated by an alarm or detector signal, at which time they descend safely to their operational position.

To be compliant, Fire Barriers must be protected from a short circuit and or total power failure, this is achieved with our patented Total Gravity Fail-Safe (TGFS) system.

FIRE RATED BARRIER WITHOUT THE REQUIREMENT OF SIDE GUIDES
4 HOUR FIRE RATED. UNLIMITED CORNERS

See the Product Matrix on pages 4 and 5 for Classifications and Maximum Width and Maximum Drops available



Installing a large FireMaster Concertina to replace a non-loadbearing wall opens up exciting design possibilities for architects and construction engineers. They are designed to activate upon receipt of a signal from either a fire alarm system or locally positioned detector. FireMaster Concertina is designed to prevent the spread of fire in accordance with BS 8524-1:2013 and is compliant to UL 10D.

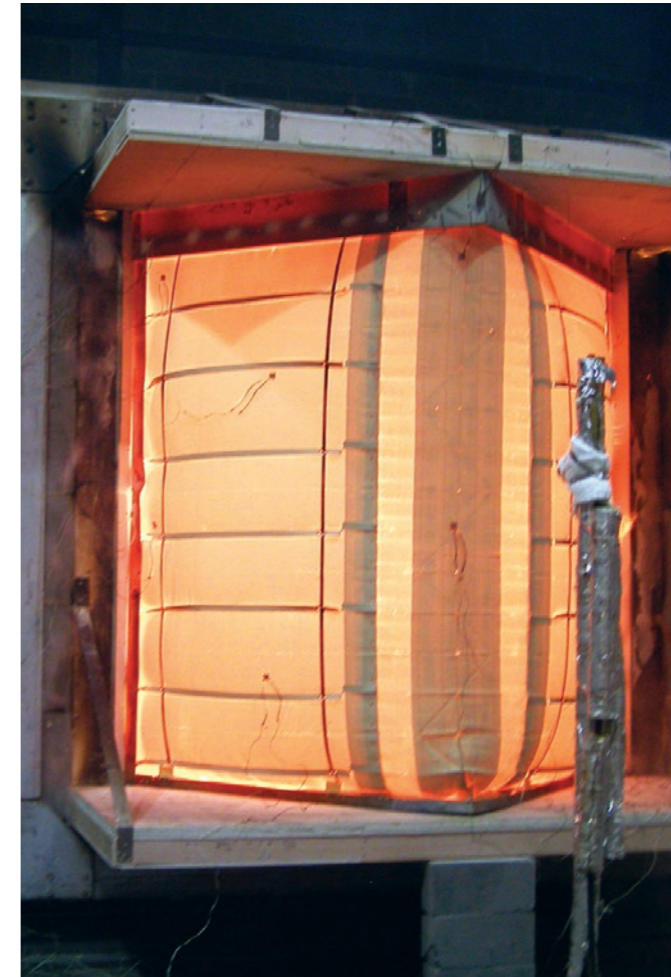
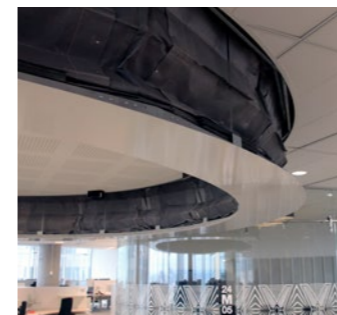
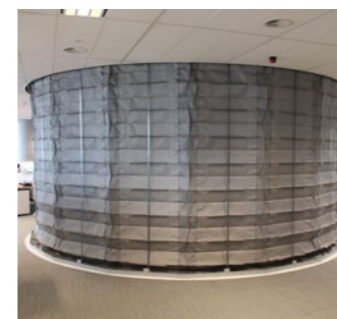
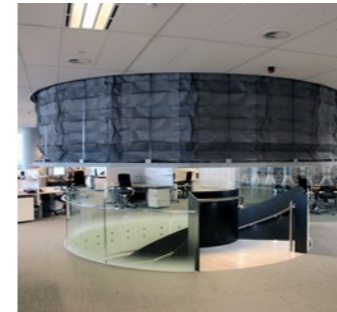
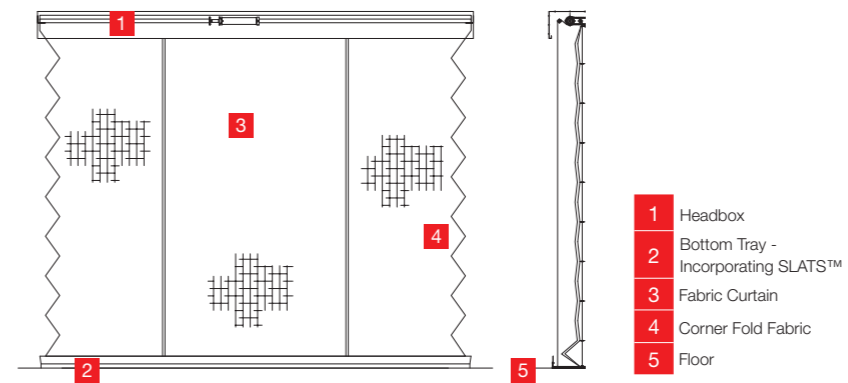

PRODUCT APPLICATION

ATRIA: Instead of fire-rated glass

STAIRS & ESCALATORS: Alternative to non-loadbearing walls

PRODUCT ADVANTAGES

- Compliant to the only fire curtains British Standard, BS 8524 Part 1
- Do not require any visible support posts at the corners
- Have unlimited spans and drops up to 8m with a small lightweight housing
- The FireMaster Concertina is available in Open and Closed shapes.
- Can be installed as a polygon, triangle, 'L' shaped right angles, curves, 'Z' shapes or even in a complete circle.
- Act as a fire separating element within the building design to prevent the passage of smoke, heat, superheated gases and fire for a predetermined period of time
- Patented TOTAL fail-safe by gravity which means they will work when required
- Ease of service

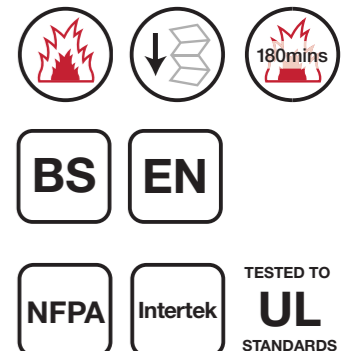

NVS™ HORIZONTAL

The horizontal range of fire curtains Coopers Fire offer an alternative way to close off stairwells and atriums. One horizontal curtain can be used instead of installing fire rated glazing or non-load bearing walls therefore creating open plan areas.

NVS stands for No Visible Supports which means the unique design allows the curtain to run under tension in a guide down each side, meaning the opening can remain free from any supports for the curtain once installed.

Coopers Fire offer two types of horizontal curtain, the Simplex and Duplex. The Simplex closes from one end to the other, whereas the Duplex is used for much larger areas and closes from each end of a void to meet and close in the middle.

FireMaster NVS Horizontal is an Active Fire Curtain Barrier Assembly comprising of technologically advanced fire-resistant fabric barriers encased in a compact steel housing. Barriers remain invisibly retracted until activated by an alarm or detector signal, at which time they close safely to their fire operational position. Fire barriers will stop and control the spread of fire in a building.

To be compliant, Fire Barriers must have a dual power supply fitted as standard. To protect from a short circuit and / or total power failure, use our patented Total Gravity Fail-Safe (TGFS) system.

COMPLETELY CLEAR VOID WITH NO VISIBLE SUPPORTS

See the Product Matrix on pages 4 and 5 for Classifications and Maximum Width and Maximum Lengths available

FireMaster NVS Horizontal is designed to prevent the spread of fire in the horizontal plane and available in a range of sizes.

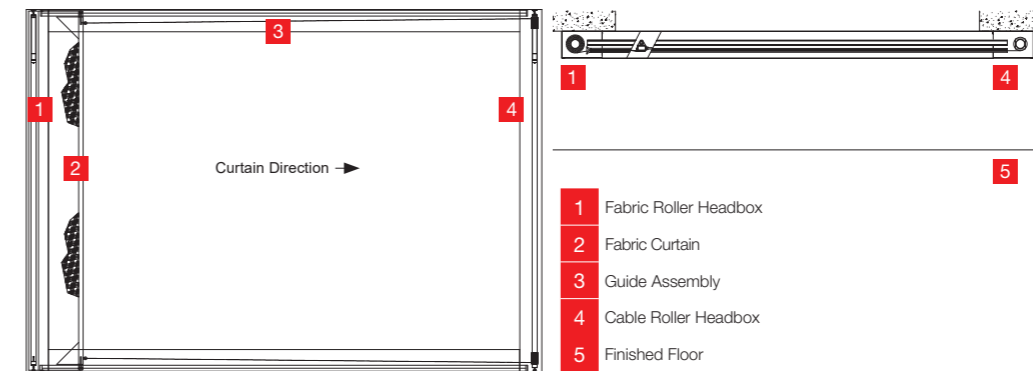

PRODUCT APPLICATION

ATRIA: Where there are more than 2 interconnected floors or the floor area exceeds 2,000m²

CEILINGS: Protect holes in ceilings or ceiling features such as heritage glass

STAIRS & ESCALATORS: Remove non-loadbearing fire-rated walls, doors or shutters

PRODUCT ADVANTAGES

- Allows for designs to create openings in floors or ceilings within a building
- Can remove the requirement for atrium provisions from the building code
- Reduced cost when compared to traditional vertical separating elements if the void opening spans many floors
- Clear unobstructed void openings without support wires traversing the opening
- Closes with mains or emergency power using low voltage drive system



PLUS NVS™ HORIZONTAL

The FireMaster Plus Horizontal offers the same benefits as the FireMaster Horizontal range except it uses the FireMaster Plus intumescent fabric. This means the FireMaster Plus Horizontal can protect from heat radiation.

FireMaster Plus NVS Horizontal is an Active Fire Curtain Barrier Assembly comprising of technologically advanced fire-resistant fabric barriers encased in a compact steel housing. Barriers remain invisibly retracted until activated by an alarm or detector signal, at which time they close safely to their fire operational position. Fire barriers will stop and control the spread of fire in a building.

To be compliant, Fire Barriers must have a dual power supply fitted as standard. To protect from a short circuit and / or total power failure.

The rollers are mounted and are driven by tubular motors. The rollers are enclosed in a steel housing and the leading edge of the curtain fabric has a supporting bar spanning between the side channels that retain the barrier.



FULL HEIGHT OPEN ATRIUM WITH NO OBSTRUCTIONS

See the Product Matrix on pages 4 and 5 for Classifications and Maximum Width and Maximum Lengths available

FireMaster Plus NVS Horizontal is designed to prevent the spread of fire in the horizontal plane and available in a range of sizes.

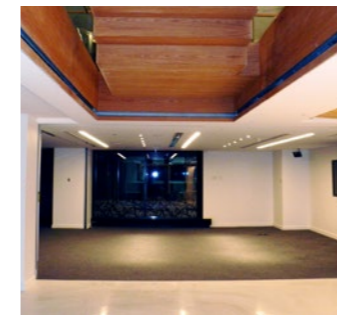
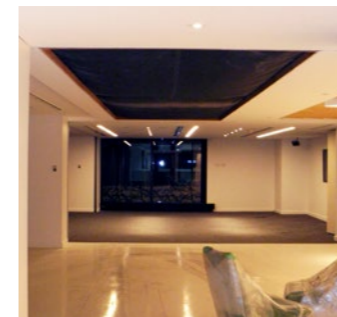
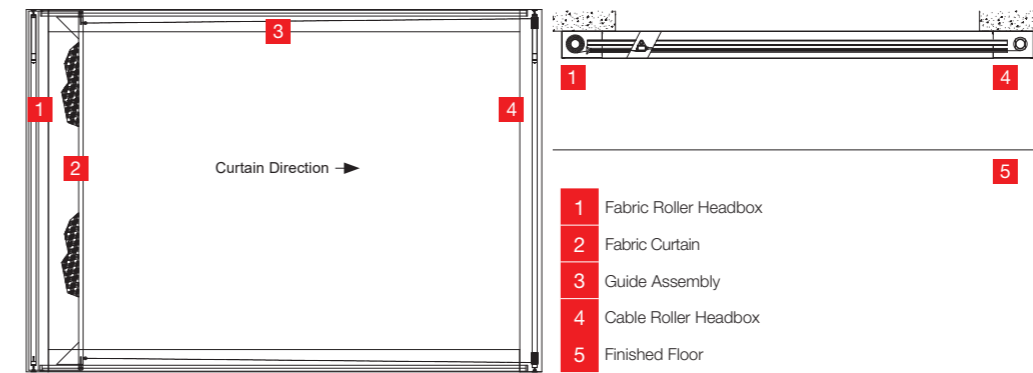

PRODUCT APPLICATION

ATRIA: Where there are more than 2 interconnected floors or the floor area exceeds 2,000m²

CEILING: Protect holes in ceilings or ceiling features such as heritage glass

MEANS OF ESCAPE: Create escape paths in fire mode only

PRODUCT ADVANTAGES

- Provides protection from heat radiation
- Allows for designs to create openings in floors or ceilings within a building
- Reduced cost when compared to traditional vertical separating elements if the void opening spans many floors
- Clear unobstructed void openings without support wires traversing the opening
- Closes with mains or emergency power using low voltage drive system

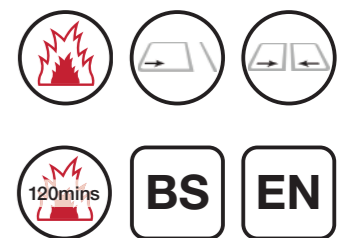

FIREMASTER®

SUPERPLUS™

The FireMaster SuperPlus is a fire curtain used in conjunction with sprinklers or drenchers to cool the surface of the curtain thus reducing the ambient temperature on the safe side of the curtain when a fire is burning on the opposing side.

The FireMaster SuperPlus fire curtain uses the same standard fabric used on the FireMaster fire curtain and used with the cooling effect of the water from the sprinklers helps to create an insulating zone for occupants to pass through safely.

FireMaster SuperPlus is an Active Fire Curtain Barrier Assembly comprising of technologically advanced fire-resistant fabric barriers encased in a compact steel housing. Barriers remain invisibly retracted until activated by an alarm or detector signal, at which time they descend safely to their fire operational position.

To be compliant, Fire Barriers must be protected from a short circuit and or total power failure, this is achieved with our patented Total Gravity Fail-Safe (TGFS) system.

Fire barriers will stop and control the spread of fire in a building. If means of escape protection is required use FireMaster Plus².

INSULATED FIRE PERFORMANCE USING SPRINKLERS
2 HOUR FIRE RATING WITH 2 HOUR INSULATION FOR UNLIMITED OPENINGS

See the Product Matrix on pages 4 and 5 for Classifications and Maximum Width and Maximum Drops available



Positioning, alignment and selection of the correct sprinkler heads is critical with only simple connection to a suitable water supply. FireMaster SuperPlus is designed to prevent the spread of fire in accordance with BS EN 1634-1:2008.

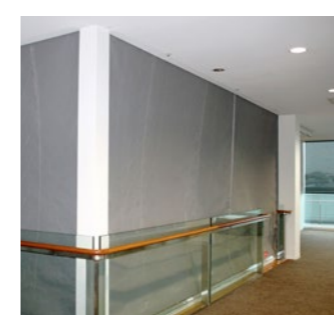
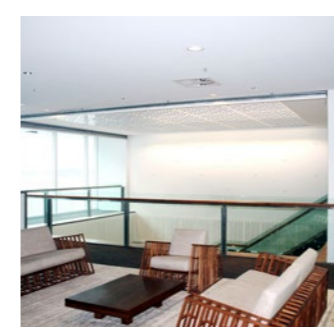
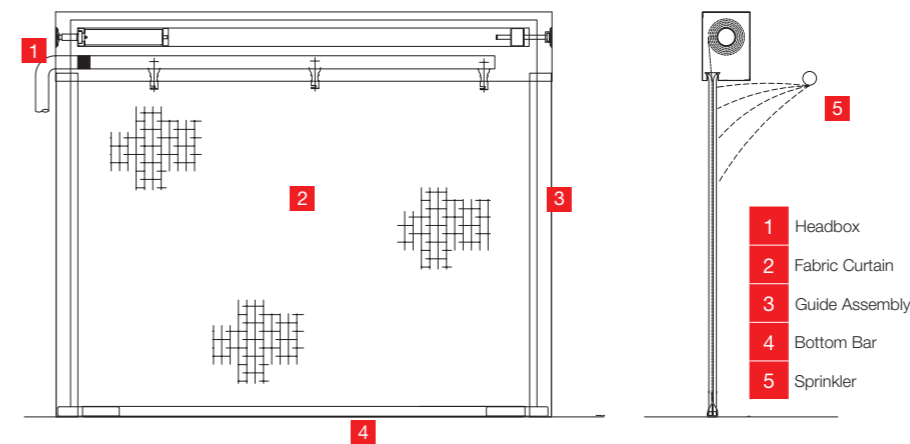

PRODUCT APPLICATION

- Protect means of escape
- Protect near combustibles
- Protect non-fire rated glass
- Basement car parks

PRODUCT ADVANTAGES

- Provides insulation performance where it is essential
- No third party drenchers required to comply
- Simple power, alarm and water connections
- Small lightweight headboxing
- Patented TOTAL fail-safe by gravity which means it will work when required
- Ease of service

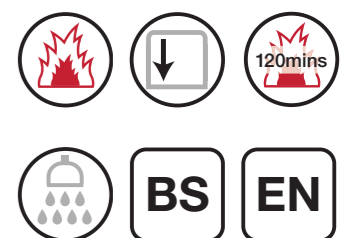

FIREMASTER®

EGRESS

The FireMaster Egress is a retractable, active fire curtain that has one or multiple soft-surface egress doors in the curtain so once it has been deployed it allows occupants to pass through.

The FireMaster Egress fire curtain utilises the standard FireMaster curtain fabric and have been tested to US standards through Intertek. The FireMaster Egress fire curtain is generally specified in countries outside of the UK and Europe as they have been tested and compliant to UL standards.

- FireMaster Egress fire curtain has a 90 minute fire rating.
- FireMaster Egress fire curtain has a 180 minute fire rating.

FireMaster Egress is a first in the industry for a fire and smoke rated curtain with one or multiple integral egress doors. The soft-surface egress door can be pushed open with less than 14kg of force applied to the interior surface. Once opened, a building occupant can easily pass through for egress. Our swinging technology also allows the soft-surface egress door to automatically return to its fully closed fire and life safety position.

The assembly is concealed in a compact overhead housing and is virtually invisible when in the retracted position. Operated by a remotely located control unit and fully synchronised with the building fire and life safety system. Upon activation the assembly gravity closes into place and is automatically reset after clearing of the fire alarm or smoke detection system.



The FireMaster Egress has been US laboratory tested and has a UL 10D rating for 180 minutes, a UL 10B rating for 20 minutes and is also UL 1784 Smoke & Draft rated.

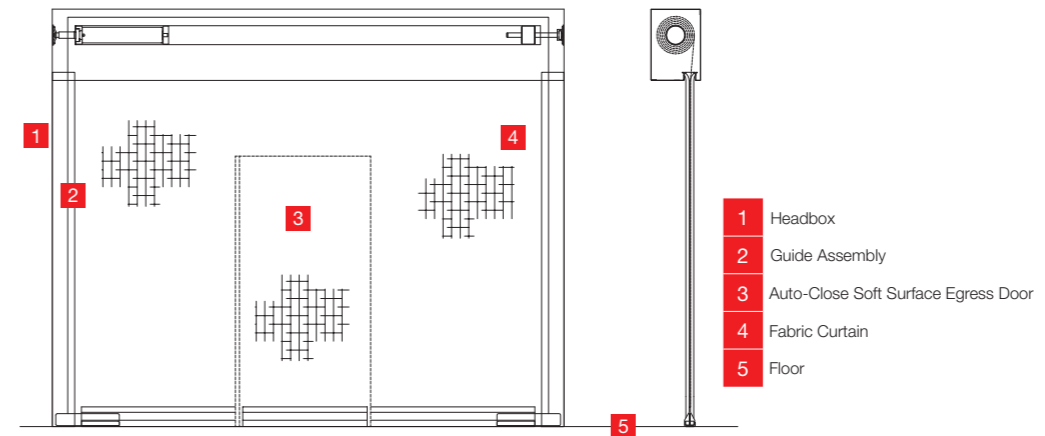

THE ONLY FIRE & SMOKE CURTAIN WITH EGRESS
TESTED TO UL STANDARDS UL 10B / 10C / 10D / 1784 TESTED

See the Product Matrix on pages 4 and 5
for Classifications and Maximum Width and
Maximum Drops available

PRODUCT APPLICATION

SHOPPING MALLS:
Replace sliding fire doors and fire

LIFTS: Protect smoke and fire spread

NON-LOADBEARING WALLS:
Open up building environments by removing non-loadbearing walls

PRODUCT ADVANTAGES

- Fire & smoke rated
- Can incorporate multiple egress doors
- Answers the question of evacuation
- Removes the requirement for emergency retract or split drop deployment
- Eliminates the requirement for the controls to be able to function during a fire event
- Allows the removal of separate exit doors

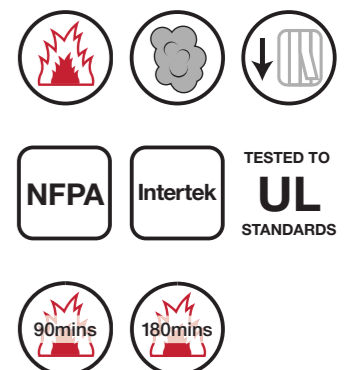

FIREMASTER®

MARINE A-0

Marine A-0 has been produced through years of testing and development. It is the only active fire curtain available specifically designed and tested for marine applications.

It is encased in a compact steel housing and will remain invisibly retracted until activated by an alarm or detector signal, at which time they descend safely under true TOTAL controlled fail-safe by gravity to its fire operational position. This feature is protected by international patent.



THE ONLY ACTIVE FIRE BARRIER FOR THE MARINE INDUSTRY
A-0 CLASSIFICATION TO IMO RESOLUTION A.754(18)

See the Product Matrix on pages 4 and 5
for Classifications and Maximum Width and
Maximum Drops available

FireMaster Marine A-0 is provided with a highly specialist technologically advanced fire-resistant fabric that when installed in our proprietary fire barrier construction is able to meet the rigorous test method of IMO Resolution A.754(18), non-combustibility and toxicity testing to IMO Resolution MSC.61(67) Annex 1, Part 2 and 3.

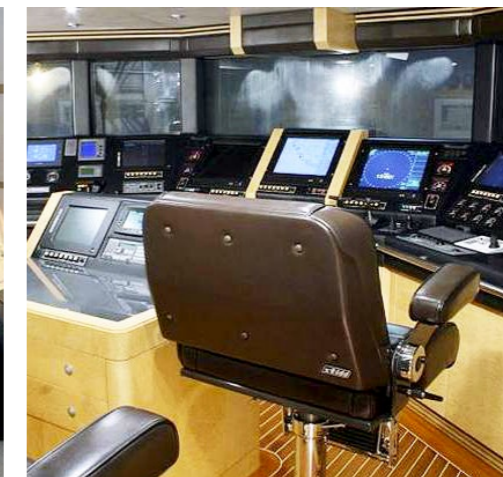
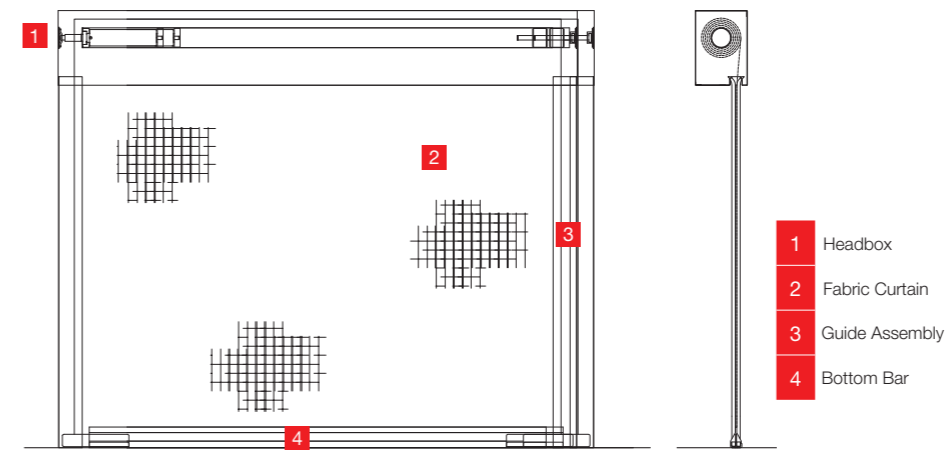

PRODUCT APPLICATION

DOORS: Replace A-0 classified doors

CORRIDORS: Replace A-0 classified doors

PRODUCT ADVANTAGES

- Small lightweight head box
- Reduces weight of ship construction materials
- Increases space availability
- Can fit in small bulkheads
- Patented TOTAL fail-safe by gravity which means they will work when required
- Ease of service



SMOKESTOP

SMOKESTOP D600A

Smoke curtains are used to control and the spread of smoke in the event of a fire. Coopers offer two types of SmokeStop curtains; the D600A and DH60. The D600A is used where smoke control and fire resistance up to 600°C is required whereas the DH60 is used where smoke control and 60mins fire resistance at temperatures greater than 600°C is required.

The SmokeStop D600A is an active smoke curtain barrier that prevents the spread of smoke for 150 minutes in the event of a fire and has been tested to a rating of D600A. This means the curtain was tested and remained intact for at least 60mins at 600°C.

Active Smoke Barriers comprise technologically advanced fire-resistant fabric barriers encased in a compact steel housing. Barriers remain invisibly retracted until activated by an alarm or detector signal, at which time they descend safely to their fire operational position.

To be compliant, Smoke Barriers must be protected from a short circuit and or total power failure, this is achieved with our patented Total Gravity Fail-Safe (TGFS) system.

Smoke Barriers will control the spread of smoke in a building and protect the means of escape and create tenable conditions.

NO NEED FOR DOWNSTANDS
UNLIMITED WIDTH, NORMALLY CONCEALED

See the Product Matrix on pages 4 and 5 for Classifications and Maximum Width and Maximum Drops available



SmokeStop Smoke Barriers are designed as barriers to prevent the spread of smoke in accordance with BS EN 12101-01:2005+A1:2006 and are classified as either DH60 or D₆₀₀A. SmokeStop is legally CE Marked in accordance with the Construction Products Regulations.

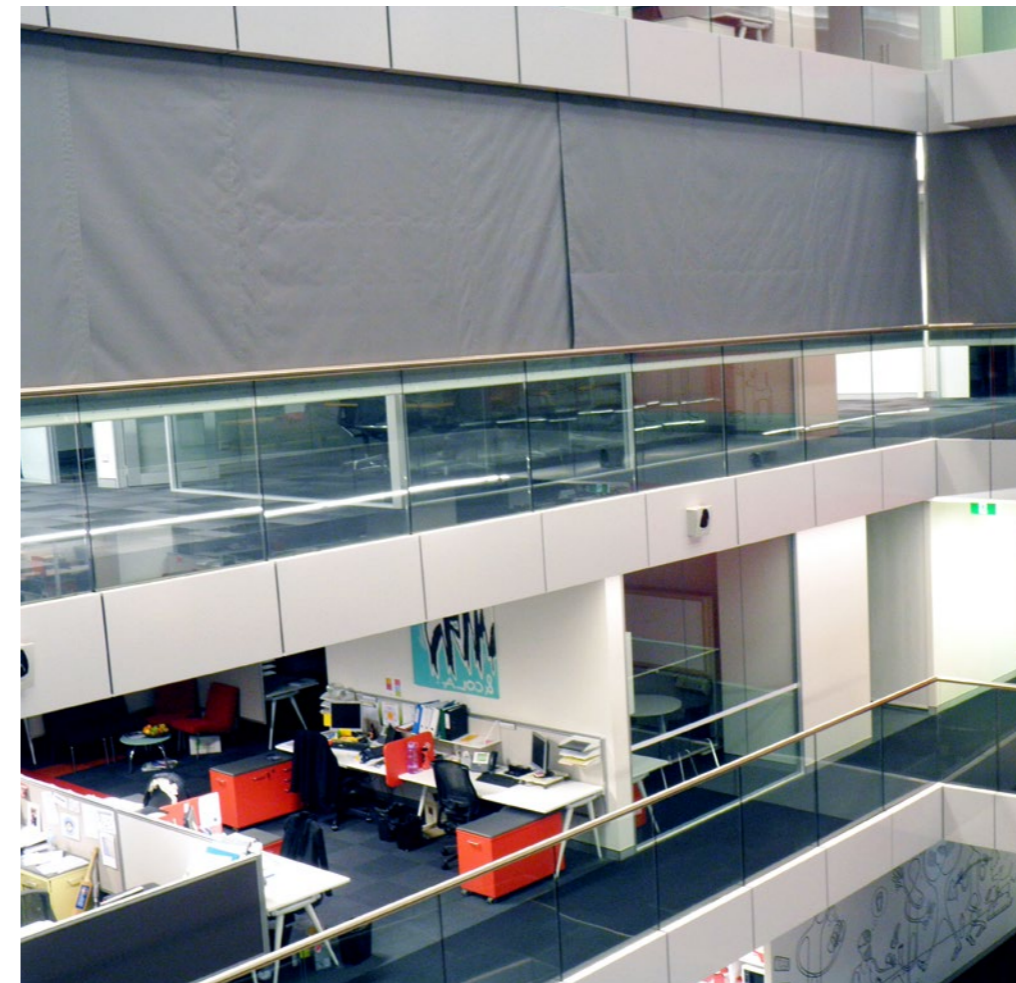
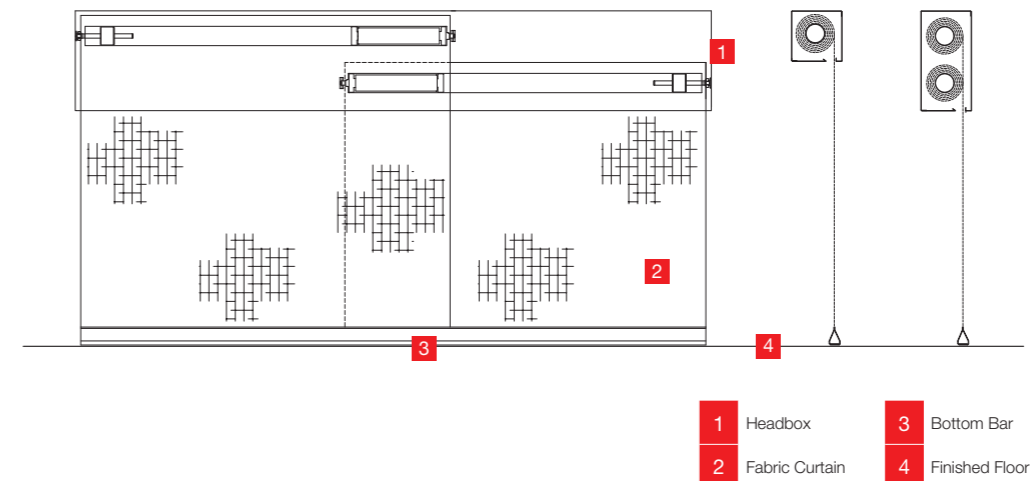

PRODUCT APPLICATION

ATRIA: Mitigate the lateral spread of smoke to multiple floors

CORRIDORS: Keep smoke near the fire source to remain hot and buoyant

STAIRS & ESCALATORS: Mitigate the spread of smoke through these openings

SHOPPING CENTRES: Smoke baffles and smoke channelling screens

PRODUCT ADVANTAGES

- Small lightweight headboxing
- Allows for uninterrupted ceiling heights. No drop down bulkheads or fixed glass smoke baffles
- Creates open spaces and increases yield of workable / chargeable floor space
- Is true fail-safe by gravity which means it will work when required
- Ease of service



SMOKESTOP

SMOKESTOP DH60

Smoke curtains are used to control and the spread of smoke in the event of a fire. Coopers SmokeStop DH60 is used where smoke control and fire resistance greater than 600°C is required.

The SmokeStop DH60 is an active smoke curtain barrier that prevents the spread of smoke for 150 minutes in the event of a fire and has been tested to a rating of DH60. This means the curtain was tested and remained intact for at least 60mins at elevated temperatures up to 1000°C.

Active Smoke Barriers comprise technologically advanced fire-resistant fabric barriers encased in a compact steel housing. Barriers remain invisibly retracted until activated by an alarm or detector signal, at which time they descend safely to their fire operational position.

To be compliant, Smoke Barriers must be protected from a short circuit and or total power failure, this is achieved with our patented Total Gravity Fail-Safe (TGFS) system.

Smoke Barriers will control the spread of smoke in a building and protect the means of escape and create tenable conditions.

NO NEED FOR DOWNSTANDS
UNLIMITED WIDTH, NORMALLY CONCEALED

See the Product Matrix on pages 4 and 5 for Classifications and Maximum Width and Maximum Drops available



SmokeStop Smoke Barriers are designed as barriers to prevent the spread of smoke in accordance with BS EN 12101-01:2005+A1:2006 and are classified as either DH60 or D₆₀₀A. SmokeStop is legally CE Marked in accordance with the Construction Products Regulations.

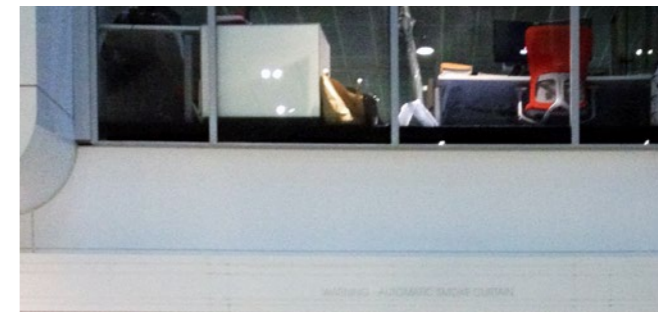
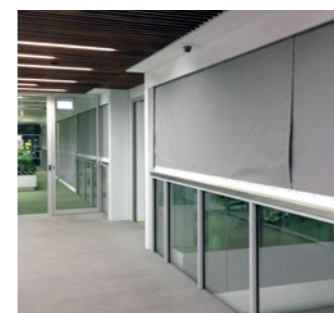
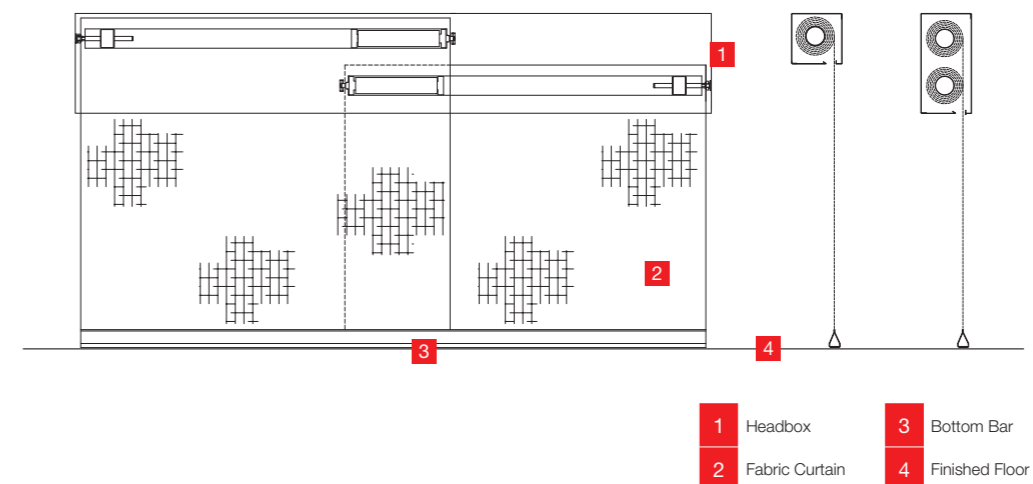

PRODUCT APPLICATION

ATRIA: Mitigate the lateral spread of smoke to multiple floors

CORRIDORS: Keep smoke near the fire source to remain hot and buoyant

STAIRS & ESCALATORS: Mitigate the spread of smoke through these openings

SHOPPING CENTRES: Smoke baffles and smoke channelling screens

PRODUCT ADVANTAGES

- Small lightweight headboxing
- Allows for uninterrupted ceiling heights. No drop down bulkheads or fixed glass smoke baffles
- Creates open spaces and increases yield of workable / chargeable floor space
- Is true fail-safe by gravity which means it will work when required
- Ease of service



SMOKESTOP

evacU8[®] D600A

SmokeStop evacU8 D600A is a unique patented bi-roller system which has interweaving, overlapped panels as narrow as 600mm wide. Each panel overlaps the other and has its own self levelling bottom ballast system. Evacuees can simply 'WALKTHRU™' the panels which then fall back into place, helped by the patented anti-tangle overlap retention system.

Active Smoke Barriers comprise technologically advanced fire-resistant fabric barriers encased in a compact steel housing. Barriers remain invisibly retracted until activated by an alarm or detector signal, at which time they descend safely to their fire operational position.

To be compliant, Smoke Barriers must be protected from a short circuit and or total power failure, this is achieved with our patented Total Gravity Fail-Safe (TGFS) system. Smoke Barriers will control the spread of smoke in a building and protect the means of escape and create tenable conditions.

STOP SMOKE IN HIGH PEDESTRIAN CONFINED SPACES SPECIFICALLY DESIGNED FOR MASS EGRESS, WITH 50% TRANSLUCENT FABRIC

See the Product Matrix on pages 4 and 5 for Classifications and Maximum Width and Maximum Drops available

SmokeStop evacU8 Smoke Barriers are designed as barriers to prevent the spread of smoke in accordance with BS EN 12101-01:2005+A1:2006 and are classified as D₆₀₀A. SmokeStop evacU8 is legally CE Marked in accordance with the Construction Products Regulations.

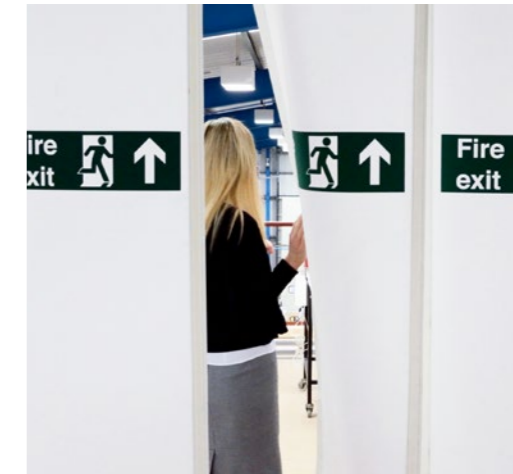
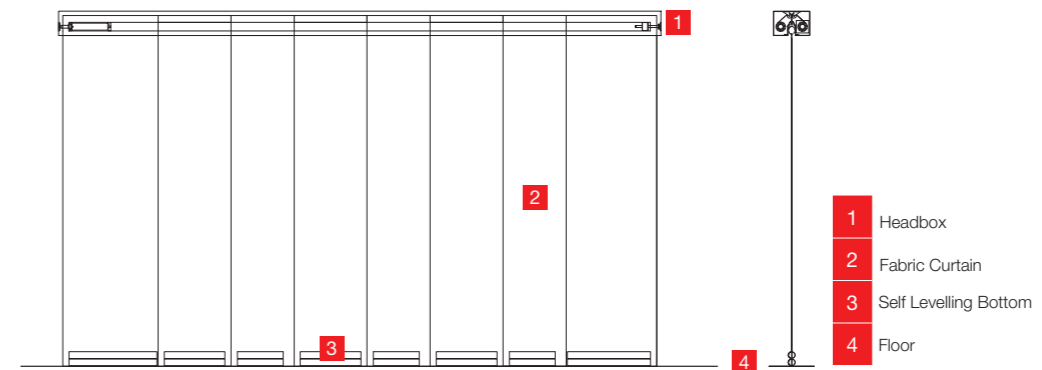

PRODUCT APPLICATION

TUNNELS: Allow occupants to escape from the smoke in confined area

CORRIDORS: Keep smoke near the fire source to remain hot and buoyant

SHOP FRONTS: Where there are limited exits

AIRPORTS & STADIA: Lots of occupants with differing abilities, limited exits

PRODUCT ADVANTAGES

- Small lightweight headboxing
- Increase tenability levels of escaping occupants
- Patented anti-tangle re-alignment & overlap retention system
- Self levelling bottom bar system to overcome uneven floors
- See through overlaps and 50% translucent panels for safety
- Patented strip retraction system to enable safe, consistent retraction



SMOKESTOP

CONCERTINA™ DH60/D60

The Coopers SmokeStop® Concertina™ is a multi-sided smoke curtain that removes the requirement for columns or corners posts. It is available in unlimited widths and available in various shapes to suit different building applications. The SmokeStop Concertina is bespoke to each project and is available in any width with a maximum drop of 6 metres.

The SmokeStop Concertina is available in Open and Closed shapes. The Open Concertina has at least one open side and requires side channels. Common Open Concertina curtains are L, U shapes. The Closed Concertina is fully enclosed and does not require side channels. Common Closed Concertina curtains are square, rectangular and circular (multi-faceted) shapes.

The unique features of the SmokeStop Concertina allow architects, fire engineers and specifiers to create open plan designs and act as part of the smoke control strategy within buildings.

The smoke and temperature resistant fabric used in the Concertina is innovatively folded to allow the fabric to stack neatly into the compact steel head box, and fall perfectly when the smoke curtain is deployed. The SmokeStop Concertina also features Coopers Fire's patented Total Gravity Fail-Safe (TGFS) system which ensures the barriers deploy by controlled descent upon initiation or during any power or system failure.

CE MARKED AND COMPLIANT TO BS EN 12101-1:2005+A1:2006
CLASSIFIED AS DH60/D60. UNLIMITED CORNERS

See the Product Matrix on pages 4 and 5 for Classifications and Maximum Width and Maximum Drops available



The unique features of the SmokeStop Concertina allow it to be used in place of traditional smoke control elements, allowing architects, fire engineers and specifiers to create open plan designs which meet all the requirements of a building's smoke control strategy.

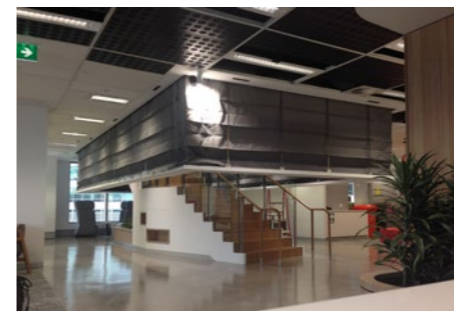
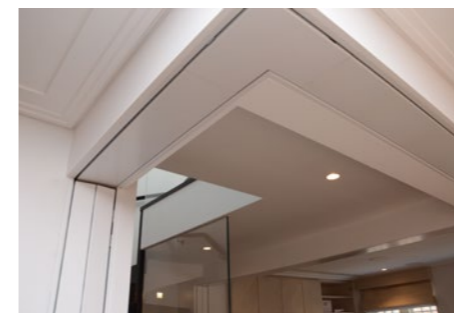
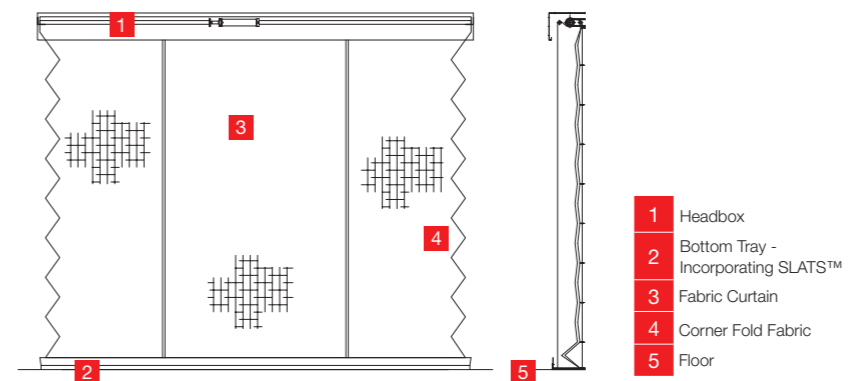

PRODUCT APPLICATION

ATRIA: Instead of glass downstands or bulkheads

SMOKE COMPARTMENTATION: Create compartments to contain smoke

PRODUCT ADVANTAGES

- Do not require any visible support posts at the corners
- Have unlimited spans and drops of 6m with a small lightweight housing
- The SmokeStop Concertina is available in Open and Closed shapes.
- Can be installed as a polygon, triangle, 'L' shaped right angles, curves, 'Z' shapes or even in a complete circle. Almost any other shape you may desire
- Act as a smoke control feature within the building design to help channel smoke
- Patented TOTAL fail-safe by gravity which means they will work when required
- Ease of service

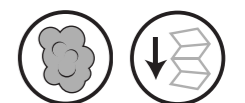

COOPERS SMOKESTOP®

DRAFT CURTAIN

The SmokeStop Draft Curtain are similar to the standard SmokeStop range but have been tested through Intertek to standards outside of the UK and Europe. The SmokeStop smoke or draft curtain is a fire and smoke rated curtain.

The SmokeStop Draft Curtain is approved to span unlimited widths and heights up to 9m (29ft) and manufactured from materials that have been tested and certified for smoke and draft rating in accordance with UL 1784.

The compact, space efficient casing encloses vertical rolling assembly with a high temperature fabric rolling curtain withstanding 204°C (400°F). The curtain remains retracted and 'invisible' until activated utilising a heavy duty bottom bar to keep the curtain in place.

Deployable Smoke & Draft Curtains comprise technologically advanced fire-resistant fabric barriers encased in a compact steel housing.

Deployable Smoke & Draft Curtains must be protected from a short circuit and or total power failure, this is achieved with our patented Total Gravity Fail-Safe (TGFS) system. Deployable Smoke & Draft Curtains will control the spread of smoke in a building and protect the means of escape and create tenable conditions.

FIRST FLEXIBLE, RETRACTABLE DEPLOYABLE SMOKE AND DRAFT CURTAIN. TESTED AND CERTIFIED FOR SMOKE AND DRAFT RATING IN ACCORDANCE WITH UL 1784

See the Product Matrix on pages 4 and 5 for Classifications and Maximum Width and Maximum Drops available



The SmokeStop Draft Curtain is a deployable smoke and draft curtain designed to prevent the spread of smoke.

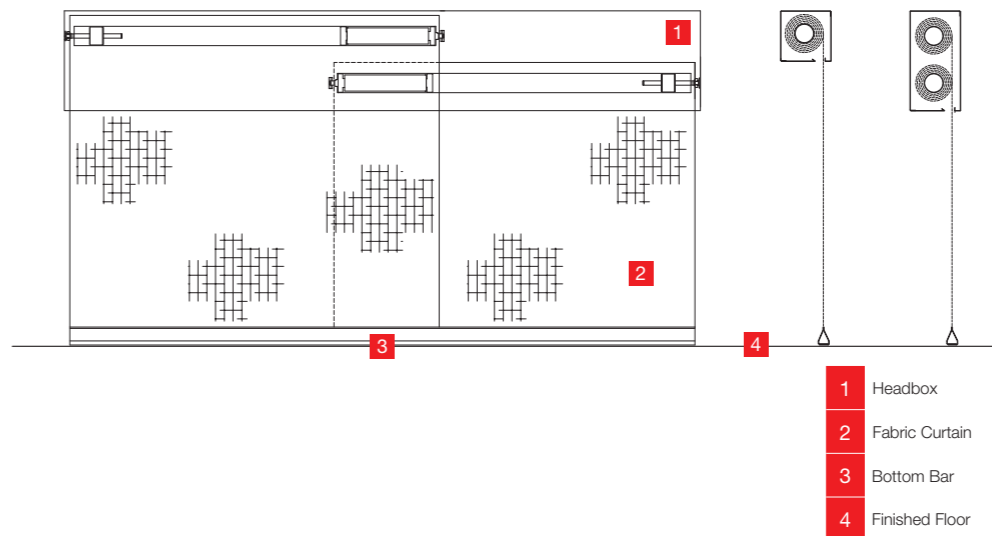

PRODUCT APPLICATION

TUNNELS: Allow occupants to escape from the smoke in confined area

CORRIDORS: Keep smoke near the fire source to remain hot and buoyant

SHOP FRONTS: Where there are limited exits

AIRPORTS & STADIA: Lots of occupants with differing abilities, limited exits

PRODUCT ADVANTAGES

- Neat, compact, 'invisible' housings
- Can be fixed directly to lightweight flexible constructions
- Oversize Certification for unlimited widths and long drops
- Unique 'Total Gravity Fail Safe' descent with auto reset after clearing of alarm system
- Compact, unobtrusive, remotely located Controls, synchronised with building's fire and life safety system
- VarioSpeed™ drive system and controls ensure the curtain operates safely with controlled descent, ascent and 'Total Gravity Fail Safe' descent



COOPERS SMOKESTOP®

EGRESS DRAFT CURTAIN

The SmokeStop Egress Curtain is a retractable, active fire rated and draft curtain that has one or multiple soft-surface egress doors in the curtain so once it has been deployed it allows occupants to pass through.

This product utilises the standard FireMaster curtain fabric that has been tested to US standards through Intertek. These curtains are specified in countries outside of the UK and Europe as they have been tested to and satisfy UL standards.

- SmokeStop Egress has a 90 minute fire rating.
- SmokeStop Egress has a 180 minute fire rating.

SmokeStop Egress Curtain is a first in the industry for a fire and smoke rated curtain with one or multiple integral egress doors. The soft-surface egress door can be pushed open with less than 14kg of force applied to the interior surface. Once opened, a building occupant can easily pass through for egress. Our swinging technology also allows the soft-surface egress door to automatically return to its fully closed fire and life safety position.

The assembly is concealed in a compact overhead housing and is virtually invisible when in the retracted position. Operated by a remotely located control unit and fully synchronised with the building fire and life safety system. Upon activation the assembly gravity closes into place and is automatically reset after clearing of the fire alarm or smoke detection system.

A DEPLOYABLE SMOKE RATED CURTAIN WITH EGRESS
TESTED TO UL STANDARDS UL 10B / 10C / 10D / 1784 TESTED

See the Product Matrix on pages 4 and 5
for Classifications and Maximum Width and
Maximum Drops available



The SmokeStop Egress Curtain has been US laboratory tested and has a UL 10D rating for 180 minutes, a UL 10B rating for 20 minutes and is also UL 1784 Smoke & Draft rated.

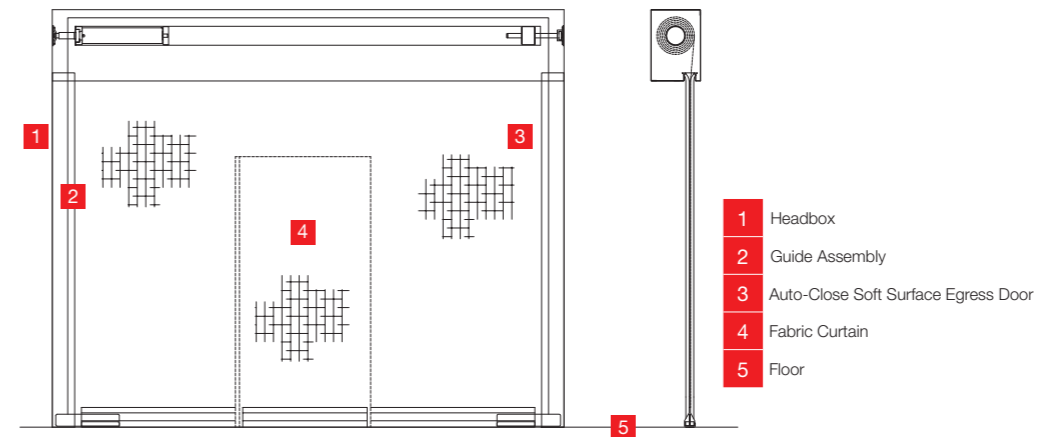

PRODUCT APPLICATION

SHOPPING MALLS:
Replace sliding fire doors and fire doors

LIFTS:
Protect smoke and fire spread

NON-LOADBEARING WALLS:
Open up building environments by removing non-loadbearing walls

PRODUCT ADVANTAGES

- Fire & smoke rated
- Can incorporate multiple egress doors
- Answers the question of evacuation
- Removes the requirement for emergency retract or deployed deployment
- Eliminates the requirement for the controls to be able to function during a fire event
- Allows the removal of separate exit doors

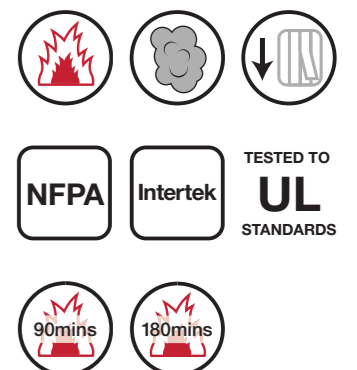

FM (DOOR, SERVE OR CABIN)

The Vii Fire product range are limited to a maximum width of 4 metres and a maximum drop of 4 metres. This range of products was introduced for use in domestic homes and areas of buildings where a compact headbox is required.

The full Vii Fire range is easy for a competent person to install and is the first and only 'plug and play' fire curtain system. This product is also aimed at kitchen serveries and due to the compactness of the Vii Fire Serve, it remains completely invisible until required.

The Vii Fire is compliant to BS 8524-1.

The Vii Fire FM is a neat compact fully automatic motorised roller system with a state of the art high temperature stainless steel reinforced curtain, tested up to 1000°C, concealed in a strong steel casing above your doorway or opening. It remains hidden but ready to work when you need it - in the event of fire.

It is easy for a competent person to install and is the first and only 'plug and play' system. To be regulation compliant they must be protected by true TOTAL power failure Gravity fail-safe.

ORIGINAL SMALL COMPACT FIRE CURTAIN
PRE-COMMISSIONED PLUG & PLAY CONTROLS

See the Product Matrix on pages 4 and 5 for Classifications and Maximum Width and Maximum Drops available



The Vii Fire FM product is designed as a barrier to prevent the spread of fire in accordance with BS EN 1634-1:2008 and BS 8524-1:2013 and is the ideal solution for small holes in fire walls.

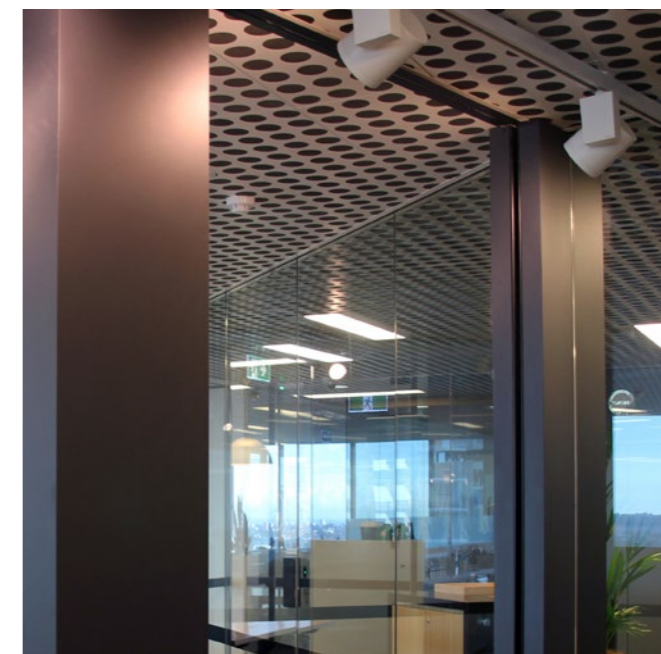
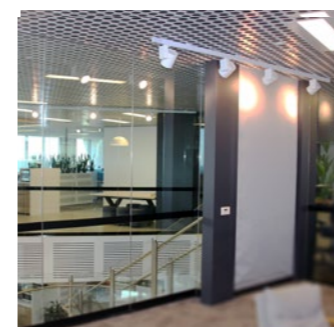
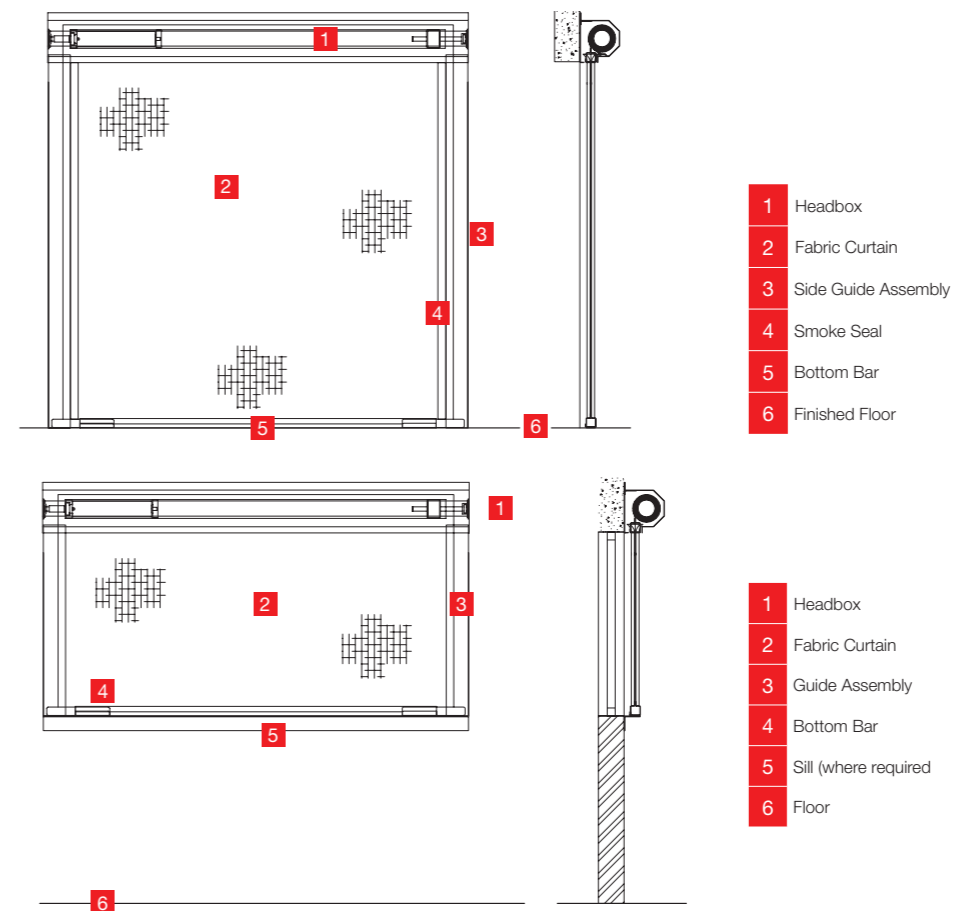

PRODUCT APPLICATION

DOORWAYS:
Remove doors that are required to be held open

SERVING HATCHES:
Protect serving hatches from fire and smoke spread

WINDOWS:
Smoke baffles and smoke channelling screens, industrial or domestic including property boundary

VENTS / AIR GRILLS:
Industrial or domestic

ELECTRICAL SUB-STATIONS:
Modular fire protection

PORTABLE BUILDINGS:
Protecting fire spread

PRODUCT ADVANTAGES

- Compliant to the only fire curtains British Standard, BS 8524 Part 1 and Part 2
- Plug and Play' pre-commissioned system
- Pre-assembled system allows for fast installation
- Face fix and reveal fix options
- Light weight and compact solution is more aesthetically pleasing than shutters or doors



iZONE

The iZone product incorporates our intumescent fabric used in the FireMaster Plus² product. The intumescent fabric expands when exposed to temperatures in excess of 160°C, forms a carbonaceous char of organic matter and consequently provides a thermal insulating barrier.

The thermal insulating barrier creates a tenable zone allowing occupants of a building to safely pass the curtain to safety with a fire burning the other side of the fire curtain.

The Vii Fire iZone is a neat compact fully automatic motorised roller system with a state of the art high temperature stainless steel reinforced curtain, tested up to 1000°C, concealed in a strong steel casing above your doorway or opening.

It remains hidden but ready to work when you need it - in the event of fire. It is easy for a competent person to install and is the first and only 'plug and play' system.

To be regulation compliant and to be fully Fit For Purpose they must be protected by total power failure Gravity Fail-Safe.

The Vii Fire iZone is compliant to BS 8524-1.

COMPACT SIZE WITH PLUG & PLAY
EASY INSTALL UP TO 4M X 4M

See the Product Matrix on pages 4 and 5
for Classifications and Maximum Width and
Maximum Drops available

The Vii Fire iZone product is designed as a barrier to prevent the spread of fire in accordance with BS EN 1634-1:2008 and BS 8524-1:2013 for such applications as protecting Means of Escape and achieves E180 EW60 (180 mins integrity and 60mins radiation).

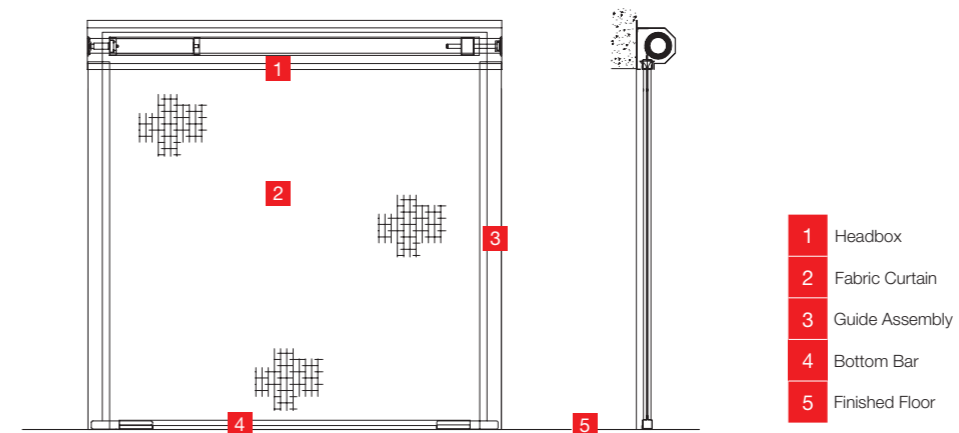

PRODUCT APPLICATION

DOORWAYS:
Remove doors that are required to be held open

CORRIDORS:
Remove bulkheads, doors, frames and jabs

SERVING HATCHES:
Protect serving hatches from fire and smoke spread

WINDOWS:
Smoke baffles and smoke channelling screens

PRODUCT ADVANTAGES

- Compliant to the only fire curtains British Standard, BS 8524 Part 1
- 'Plug and Play' pre-commissioned system
- Pre-assembled system allows for fast installation
- Face fix and reveal fix options
- Achieves radiated heat as low as 6kW/m after 60 minutes.
- Light weight and compact solution is more aesthetically pleasing than shutters or doors

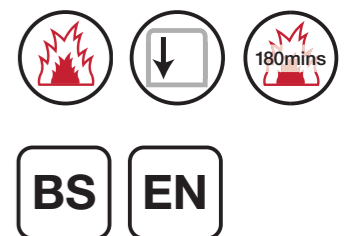

VARIOSPEED®6

CONTROLS AT MOTOR (CAM)

The Variospeed®6 system is used for Smoke / Fire Curtain(s) fitted with 24Vdc permanent magnet electrical motors fitted with an internal 24Vdc electromagnetic brake, as standard. When the Smoke / Fire curtain(s) are fully retracted, the internal electromagnetic brake is powered, keeping the Smoke / Fire curtain(s) in their retracted position. Power to the motor is completely isolated, prolonging the life of the motor and maintaining manufacturers supply warranty.

The motors include built in short circuit and open circuit protection, meaning the curtains will deploy under Total Controlled Gravity Failsafe at a descent rate compliant with standards BS EN 12101 and BS 8524 even if the motor wires are severed, i.e. shorted together or disconnected from the Motor Control Card (MCC). In the event of an alarm activation the electromagnetic brake will de-energise and the Smoke / Fire curtain(s) will immediately deploy to their Fire Operational Position (FOP) under Gravity Failsafe.

If there is a mains power failure the Smoke / Fire curtain(s) will be held in the retracted position for 30 minutes (adjustable) under Battery Backup (BBU) before deploying to their Fire Operational Position (FOP). If an alarm activation is received during a mains power failure, the curtain(s) will immediately deploy to their Fire Operational Position (FOP). The Smoke / Fire curtain(s) will descend under total & controlled Gravity Failsafe.

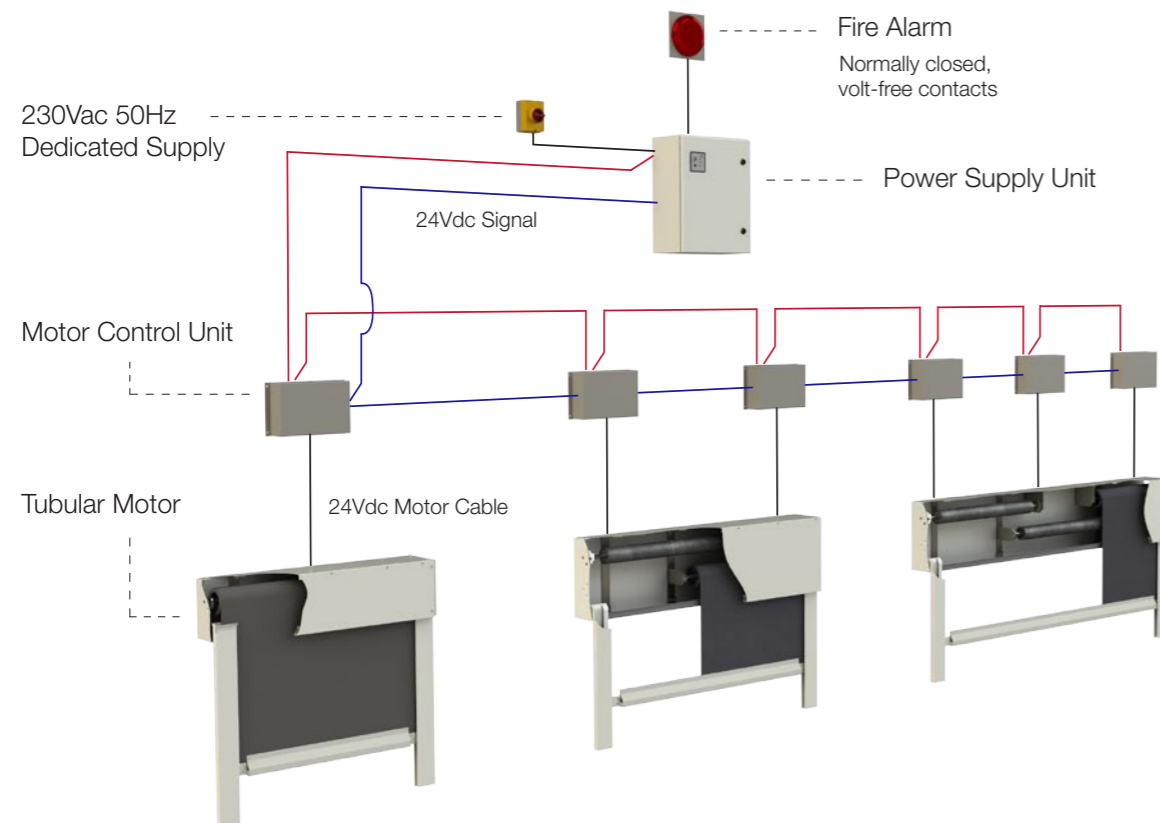

PRODUCT FEATURES

- "Slave line" for overlapping / multiple roller systems
- Up to 20 fire / smoke curtain rollers from 1 Power Supply Unit (PSU)
- 24Vdc motors with internal electromagnetic brakes as standard
- Motor protected from short circuits or open circuits
- Can be connected to BMS for monitoring of system
- Adjustable electronic descent speeds
- Adjustable battery backup
- Multiple alarm inputs and outputs
- Low power consumption

VARIOSPEED®6

CONTROLS GROUPED (CG)

Up to 4 Motor Control Cards (MCC's) can be incorporated inside the 500(h) x 400(w) x 210(d) cabinet. The size of the BBU CG cabinet can be increased to accommodate a greater number of Motor Control Cards (MCC's).

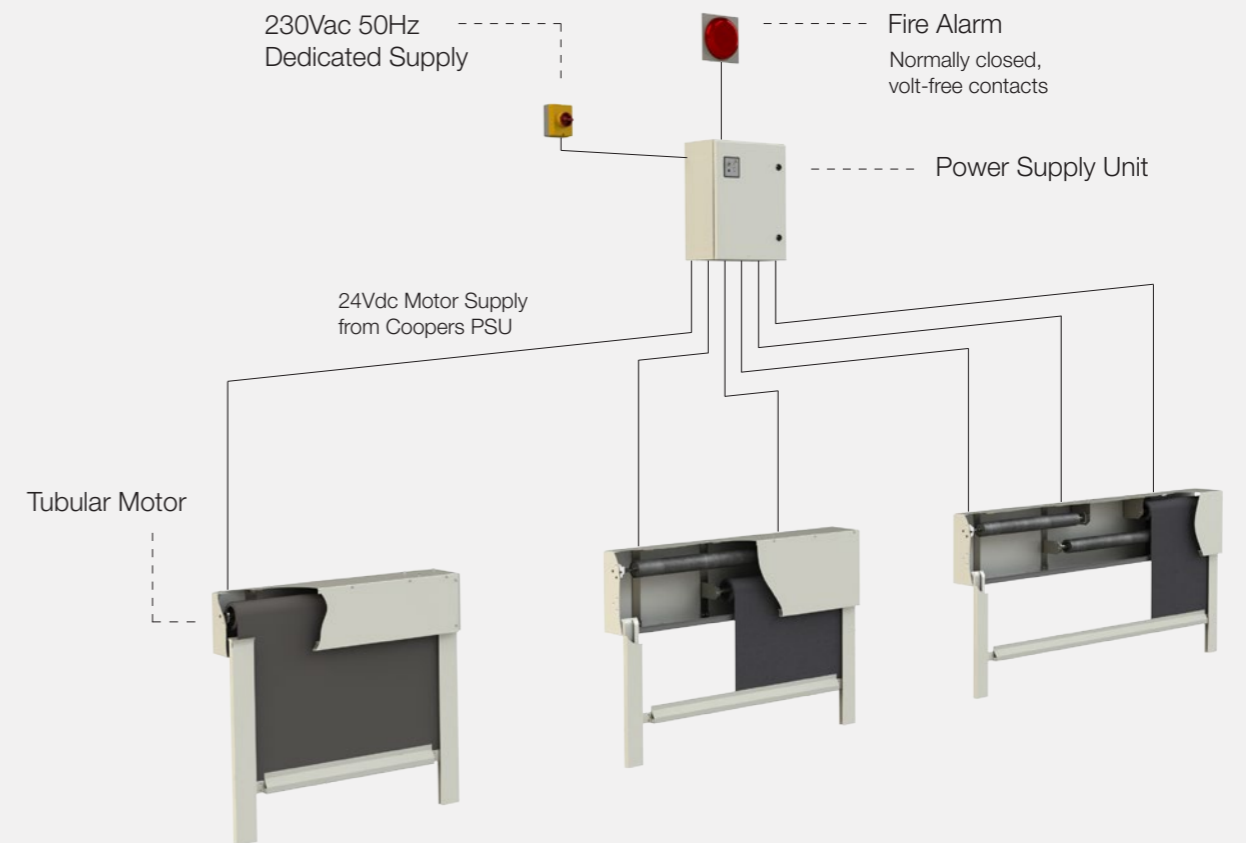

PRODUCT FEATURES

- "Slave line" for multiple / overlapping roller systems
- Low power consumption
- All electrical controls within one enclosure
- Less service and maintenance access requirements
- Simple field wiring and connections
- 24Vdc motors with internal electromagnetic brakes as standard
- Adjustable electronic descent speeds
- Adjustable soft final opening
- Motor protected from short circuits or open circuits
- Adjustable battery backup
- Can be connected to BMS for monitoring of system

MONO MK5 CONTROL

PLUG AND PLAY

The Mono Control Unit is a compact single curtain controller with a complete range of incorporated ancillary control options. The system is completely 'plug and play', which means all wiring terminations can be connected quickly and efficiently, reducing installation times and complexity. The system also incorporates a 'self-test' facility, enabling the system to monitor it's performance and maintaining a safe system.

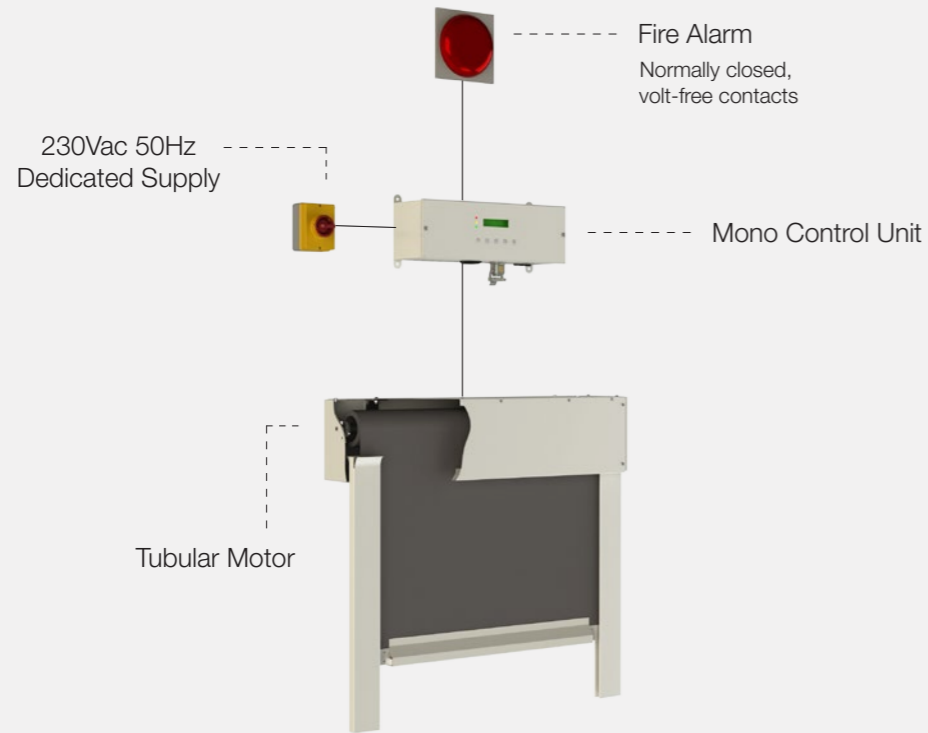

PRODUCT FEATURES

- Low power consumption
- Small, compact enclosure
- Complete "plug and play" wiring and terminations, simple to connect
- 24Vdc motors with internal electromagnetic brakes as standard
- Adjustable electronic descent speeds
- Motor protected from short circuits or open circuits
- Adjustable battery backup
- Enabled for 'Self-Test'
- Programmable and adjustable Split Drop Delay
- Programmable and adjustable Dual Drop
- Programmable Timed Emergency Retract
- Fireman's Override
- Fault and Event Log



CONTROLS

OPTIONAL EXTRAS

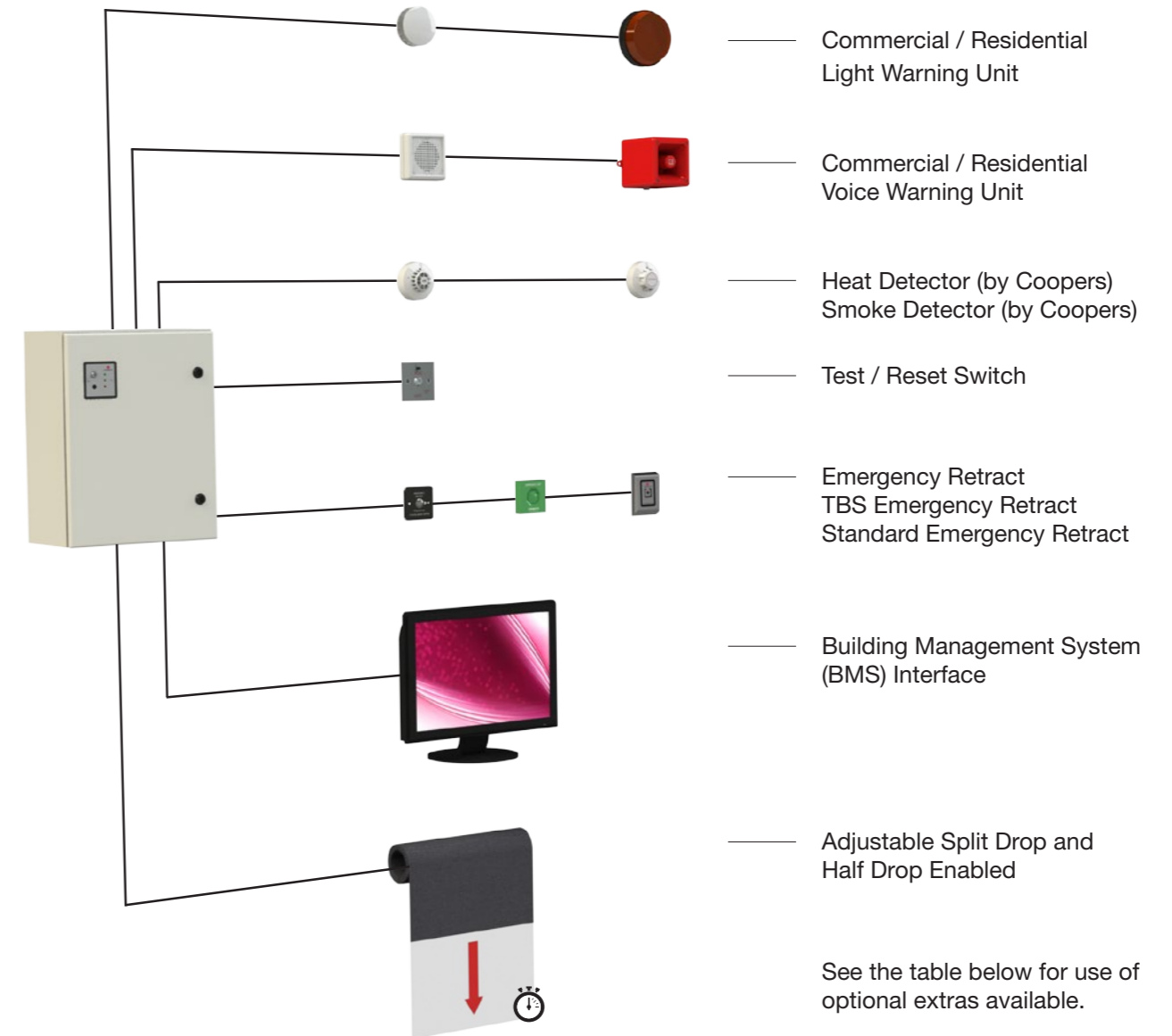

See the table below for use of optional extras available.

OPTIONAL EXTRAS MATRIX

Optional Extras	Control Panel Type			Datasheet Reference
	MONO	BBU	ERU	
Light Warning Units	✓	✓	✓	Visit Coopers Fire website at www.coopersfire.com Click on Downloads section and go to Datasheets - Controls and Ancillaries to view or download all Optional Extras
Voice Warning Units	✓	✓	✓	
Heat Detector / Smoke Detector	✓	✗	✓	
Test / Reset Switch	✓	✓	✓	
Emergency Retract Push Buttons	✓	✗	✓	
BMS Interface	✓	✓	✓	
Adjustable Split Drop and Half Drop Enabled	✓	✓	✓	
Safety Edge / Bump Stop	✓	✓	✓	

For information, to get a quote
or to book a CPD workshop

Please call:

+44 (0)2392 454 405

or E-mail: info@coopersfire.com
WWW.COOPERSFIRE.COM

Coopers Fire Ltd,
Edward House, Penner Road,
Havant, Hampshire, PO9 1QZ
United Kingdom

Phone: +44 (0)2392 454 405
Email: info@coopersfire.com
Web: www.coopersfire.com

Coopers Fire Ltd has a policy of
continuous product improvement.

As such we reserve the right to
change design and specifications
without prior notice.

Please check our website for the
latest information.

© Coopers Fire Ltd. All content and products are copyright
of Coopers Fire Ltd. Registered in England Number: 2010274.
Multiple patents granted and pending.

Series 2 v14 Aug 2019

L&F A Lowe & Fletcher Group Company



LEADING THE WAY IN FIRE PROTECTION